



INVESTOR PRESENTATION



Highlights

Financials, Traffic, Tariff Increase and Regulatory Framework

FINANCIALS

		Gruppo SIAS	Gruppo ASTM
FY 2015	Revenues	1,088 (+5.9%)	1,104 (+6.1%)
	EBITDA	646 (+6.1%)	646 (+5.2%)
	Group Net Income	161 (+12.2%)	108 (+8.4%)
	Investments	208	208
	Net Financial Indebtedness	1,581	1,246
Q1 2016	Revenues	242 (+6.2%)	245 (+5%)
	EBITDA	144 (+9.3%)	142 (+6.8%)
	Investments	41	41
	Net Financial Indebtedness	1,777	1,197

TRAFFIC

FY 2015: **+3.17%**

Q1 2016: **+6.19%**

TARIFF INCREASE

FY 2015 : **+1.50%** (for all motorway stretches)⁽¹⁾

FY 2016:
 - SATAP S.p.A. A4: **+6.50%**
 - OTHER MOTORWAYS: temporary suspended⁽²⁾

REGULATORY FRAMEWORK

Interlocutions with MIT and with the EU in order to find a solution and an economic and financial balance for the financial plans **based on extensions** in line with the French model and framework.

Recently **CIPE** gave the greenlight – with some provisions – to MIT in order to release the **approval** on the SATAP A-21, ADF, SALT, SAV, ATS and SITAF **Financial Plans**.

(1) Temporary suspension waiting for the updates of the financial plans of each "single" Group licensee that has still to be approved. Lower revenues achieved in 2015 (due to the lower toll increase applied) will be recovered, with no change in the financial effects.

(2) The recovery of the toll adjustment for the period of suspension from 1 January 2016 to the issue date of the Decrees approving the Economic-Financial Plans will be recognised on approval of the toll adjustment for 2017.



Highlights

Business Development

31 August 2016

Contractual Termination of ATIVA ⁽¹⁾ Concession - Ongoing management of the Concession till entering of a new Coincessionaire and cash in of the Terminal Value

1 July 2016

Effective entering of **Itinera (constructions) under ASTM Group** perimeter

4 May 2016

Closing of the acquisition of **joint control of Ecorodovias with price reduction**

16 May 2015

Inauguration and Traffic opening of the 32 km-long motorway route managed under concession by **T.E. S.p.A.**

13 May 2015

Awarding of the concession concerning the **"A21 Piacenza - Cremona - Brescia"** motorway.

(1) SIAS equity interest: 41.2% - Not consolidated in accordance to line by line method (consolidated in accordance to equity method)

- Subsidiaries consolidated with the line-by-line method
- Equity investment

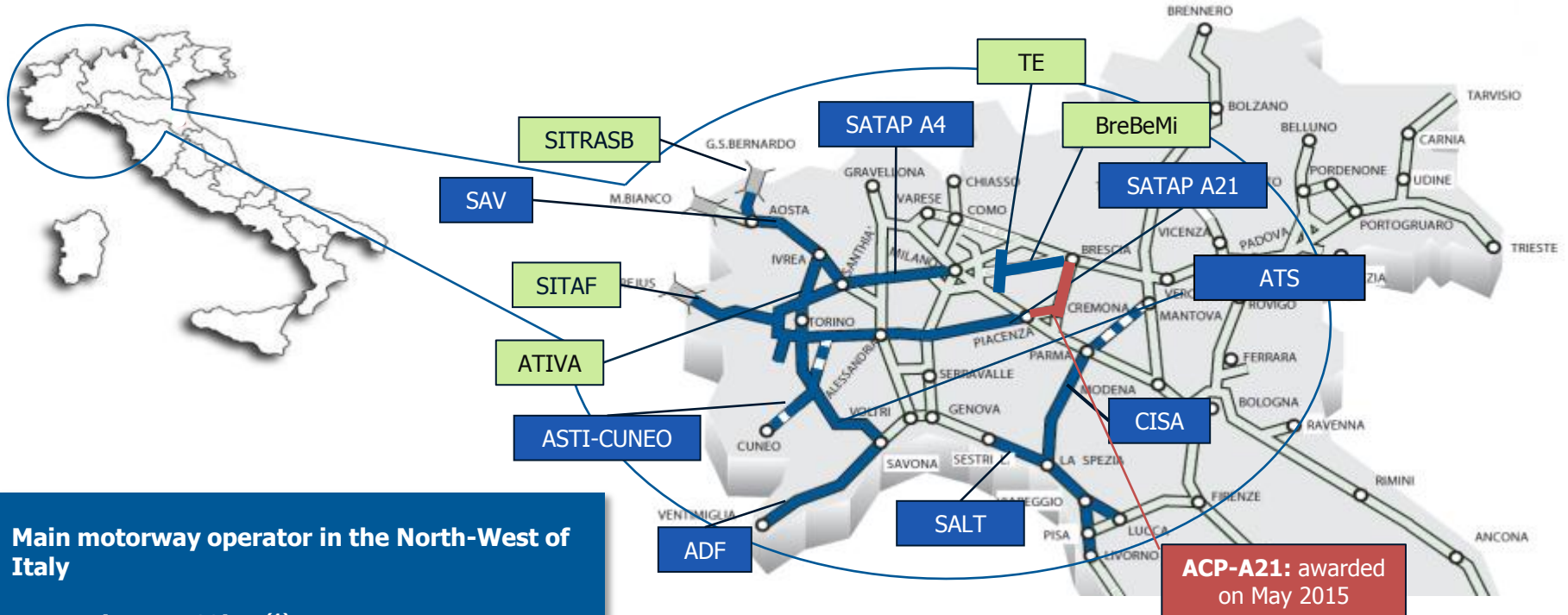

Main motorway operator in the North-West of Italy

Network: ~1,460km ⁽¹⁾
 (of which ~104 under construction) equal to approximately 22% of the national grid

Average remaining duration of the concessions:
 ~ **11 years**

(1) Including the stretch ACP-A21 recently awarded.
 1,545km including 84 km related to the stretch NewCastle-Carlisle (UK)



Highlights

Italian network^(**) – cont.

	Concessionaire	Link	% owned (direct stake)	Km	Concession Expiry	FY 2015 net motorway revenues (€m)	FY 2015 EBITDA (€m)	EBITDA margin	% Group EBITDA	
Subsidiaries	SATAP	A4 Turin – Milan	99.87%	130.3	2026	211.2	151.5	68%	24.8%	43.3%
		A21 Turin – Piacenza		167.7	2017	164.1	113.6	63%	18.5%	
	SALT	Sestri Levante - Livorno, Viareggio - Lucca e Fornola - La Spezia	95.23%	154.9	2019	179.1	121.8	63%	19.9%	
	CISA	La Spezia - Parma (and junction to Brennero motorway)	99.34%	182 ⁽¹⁾	2031	94.2	56.1	54%	9.1%	
	ADF	Savona – Ventimiglia	68.30%	113.2	2021	149.9	92.7	57%	14.8%	
	SAV	Quincinetto – Aosta	65.08%	59.5	2032	65.9	45.6	61%	7.4%	
	ATS	Turin – Savona	99.98%	130.9	2038	64.2	32.3	46%	5.3%	
	ASTI-CUNEO	Partly under construction	60.00%	78 ⁽²⁾	⁽³⁾	17.7	1.3	Nm	0.2%	
Equity investments	ATIVA	Turin ringroad, Turin-Quincinetto, Ivrea - Santhià & Turin – Pinerolo	41.17%	155.8	2016	120.9	72.1	-	-	
	SITAF	Frejus tunnel, Turin – Bardonecchia	36.53%	94	2050	122.4	75.9	-	-	
	SITRASB	Gran San Bernardo tunnel	36.50%	12.8	2034	11.1	4.9	-	-	
	TE ⁽⁴⁾	Milan external ringroad	8.4% ⁽⁵⁾	32 ⁽⁶⁾	2065	24.2	9.8	-	-	
	BreBeMi ⁽⁴⁾	Brescia – Bergamo - Milan	⁽⁷⁾	62	2039 ⁽⁸⁾	-	-	-	-	

(1) Inclusive of the planned 81km stretch linking Parma to Brennero motorway

(2) Inclusive of 23km under construction

(3) 23.5 years starting from completion of the infrastructure

(4) Joint control with Intesa Sanpaolo

(5) Plus indirect stake of 47.7% held through TEM in which the group own a 40% stake (plus 7.2% held directly by the affiliate company Itinera)

(6) Full opening to traffic on 16 May 2015. The first section (so called Arco TEEM of 7km) opened in July 2014

(7) Indirect stake of 79% held through Autostrade Lombarde in which the group own a 13.3% stake (plus 2.2% held directly by the affiliate company Itinera)

(8) Original expiry 2033 - Ongoing extension

(**) Centropadane recently awarded non included

A vertical list of six items, each preceded by a number inside a circle. The items are connected by a thin line that starts at the top left of the first item and zig-zags down to the bottom left of the sixth item. The first item, 'Financial Results', is highlighted with a light beige background, while the others have a dark blue background.

- 1** Financial Results
- 2** SIAS Group Financial Structure
- 3** Operating Activities
- 4** Regulatory framework
- 5** Business development
- 6** Appendix



Financial Results

SIAS Group – FY 2015 / Q1 2016 Delivering sound growth

FY 2011 - 2015

(€mln)	2011	(1)(2)2012	2013	2014	2015	CAGR
Revenues	939	868	977	1,027	1,088	3.0%
of which net toll revenues	820	769	857	904	945	2.9%
EBITDA (recurring)	576	530	566	609	646	2.3%
EBIT	325	300	314	322	357	1.9%
Group net profit	153	496	139	143	161	1.0%
Net debt	(1,756)	(1,489)	(1,670)	(1,644)	(1,581)	
Operating cash flow	403	399	395	421	458	
Capex	281	265	283	224	208	
DPS (€)						
- Ordinary	0.41	0.33	0.30	0.32	0.32	
- Extraordinary	-	-	-	-	-	
Pay-out (%)	61%	48%	49%	51%	45%	

2015's results consolidate the growth path of recent years

Q1 2013 – Q1 2016

(€mln)	Q1 2013	Q1 2014	Q1 2015	Q1 2016	CAGR
Revenues	200	222	228	242	6.5%
of which net toll revenues	179	196	201	216	6.4%
EBITDA (recurring)	108	129	132	144	10.0%
Net debt	(1,512)	(1,658)	(1,678)	(1,777)	
Capex	64	47	56	41	

(1) Starting 2012, ATIVA S.p.A. and its Group have been assessed according to the "equity method" (in previous financial years, it was consolidated according to the "proportional method"). In order to provide comparable figures, 2012 figures have been recalculated.

(2) 2012 revenues contains Autostrade Sud America S.r.l. capital gains.



Financial Results

SIAS Group – FY 2015 EBITDA

(€mln)	FY 2015	FY 2014	Change
Motorway sector	612.9	579.7	33.2
Construction/Engineering sector	5.0	4.8	0.2
Technology sector	30.9	28.6	2.3
Car Parks sector	2.8	-	2.8
Services (holdings)	(5.7)	(4.5)	(1.2)
EBITDA	645.9	608.6	37.3
Non recurring items	5.8	(10.2)	16.1
EBITDA adj.	651.7	598.4	53.4
<i>Ebitda margin motorway sector</i>	56%	56%	

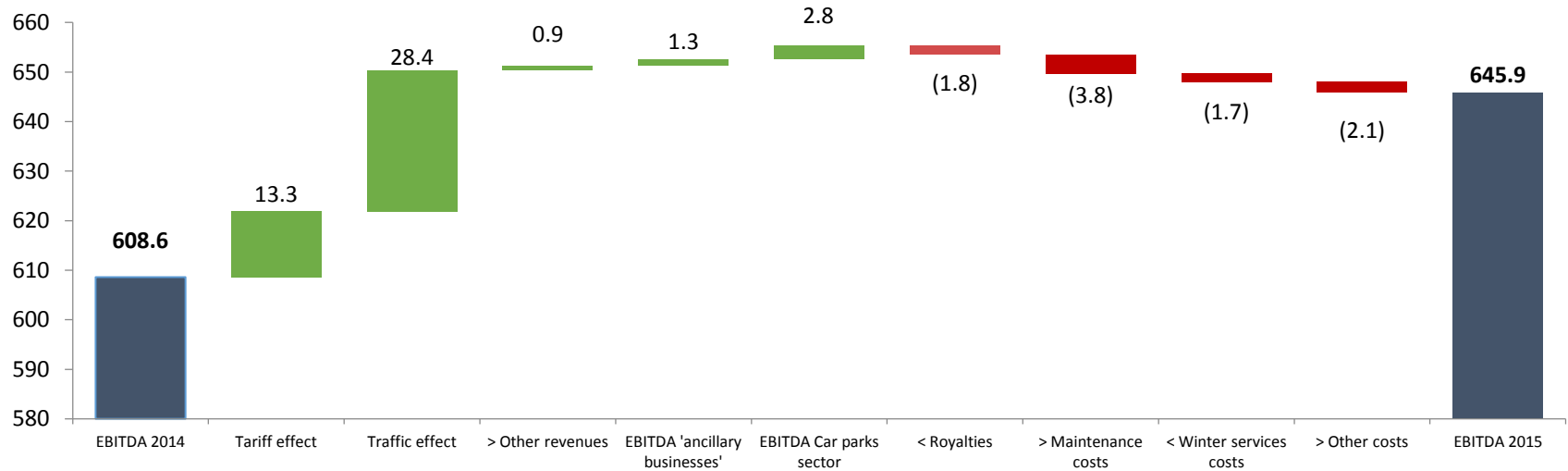



Financial Results

SIAS Group – Q1 2016 EBITDA

(€mln)	Q1 2016	Q1 2015	Change
Motorway sector	139.7	127.5	12.2
Construction/Engineering sector	1.1	0.8	0.3
Technology sector	4.2	4.5	(0.3)
Car Parks sector	0.3	0.3	-
Services (holdings)	(1.2)	(1.2)	-
EBITDA	144.1	131.9	12.2
<i>Ebitda margin motorway sector</i>	58%	56%	

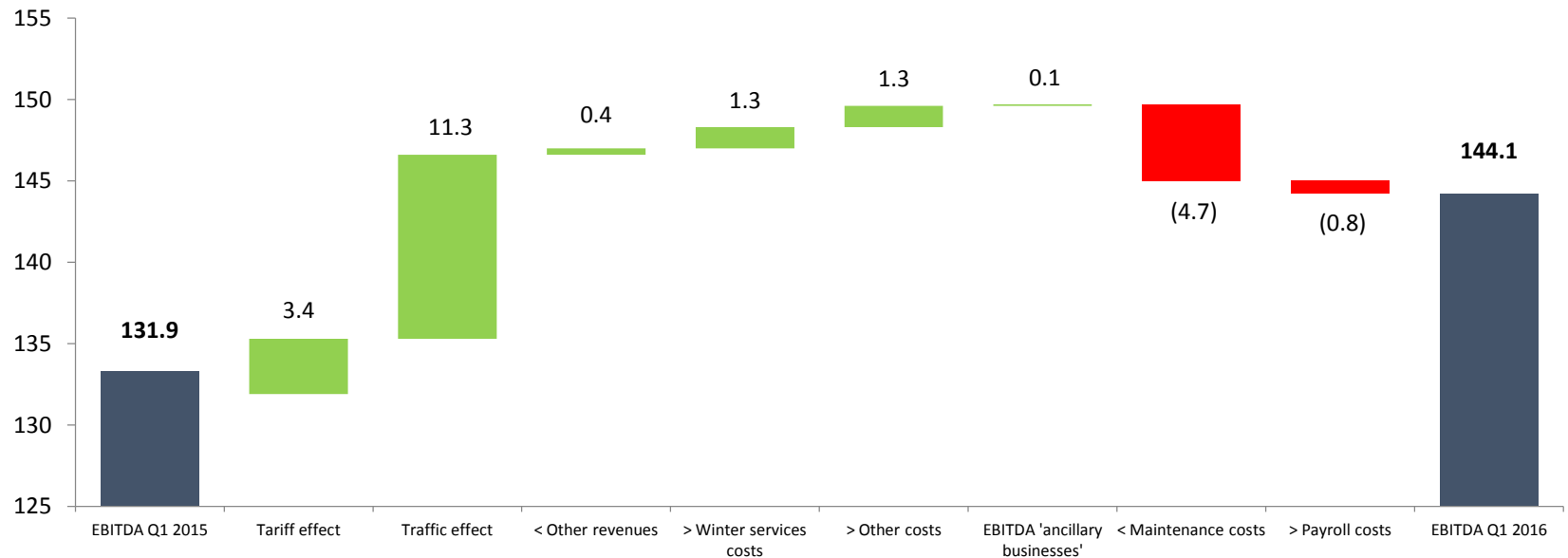



Financial Results

SIAS Group – FY 2015 Group net profit

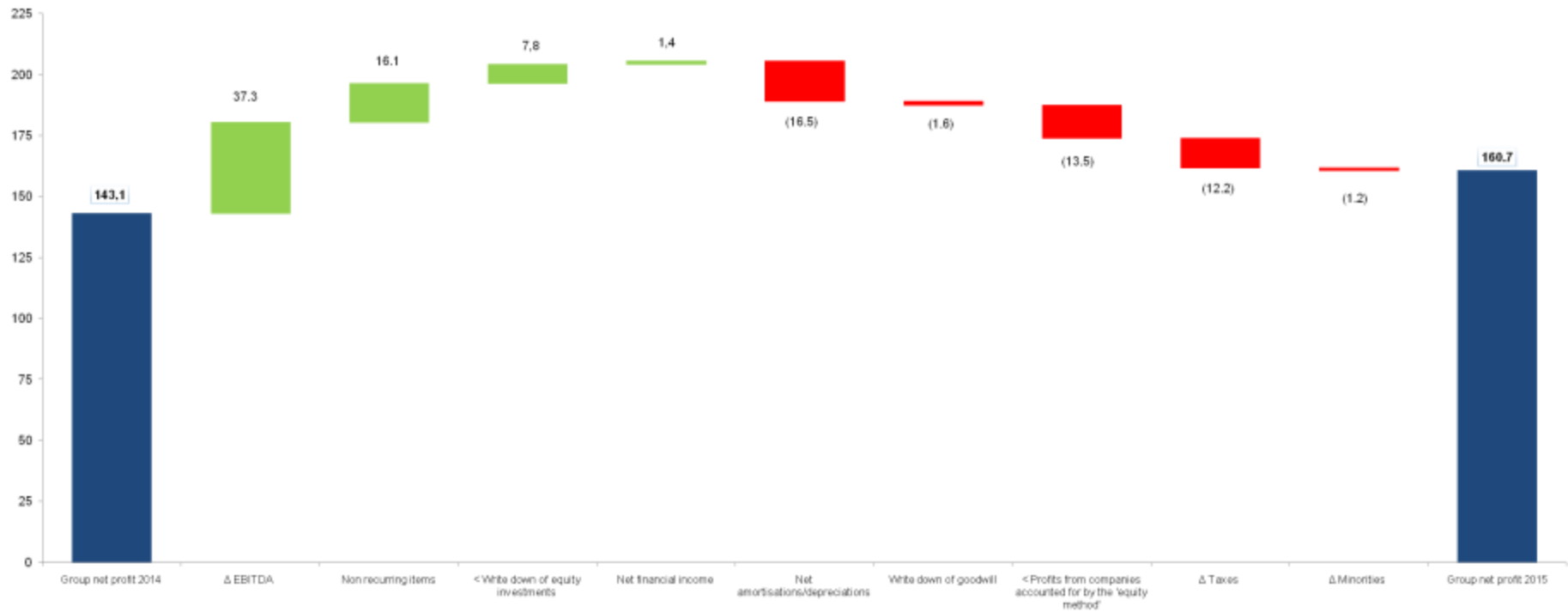



Financial Results

SIAS Group – Net Financial Position

(€mln)	31.12.2014	31.12.2015	31.03.2016
Liquidity	1,099	954	778
Financial receivables	492	470	458
Current net financial indebtness	(376)	(241)	(292)
Current net cash	1,215	1,183	944
Non current net financial indebtness	(2,672)	(2,635)	(2,590)
Net financial indebtedness	(1,458)	(1,452)	(1,646)
Non current financial receivables	49	49	50
Discounted value of the payable due to ANAS - Central Insurance Fund	(236)	(178)	(181)
Adjusted net financial indebtedness	(1,644)	(1,581)	(1,777)

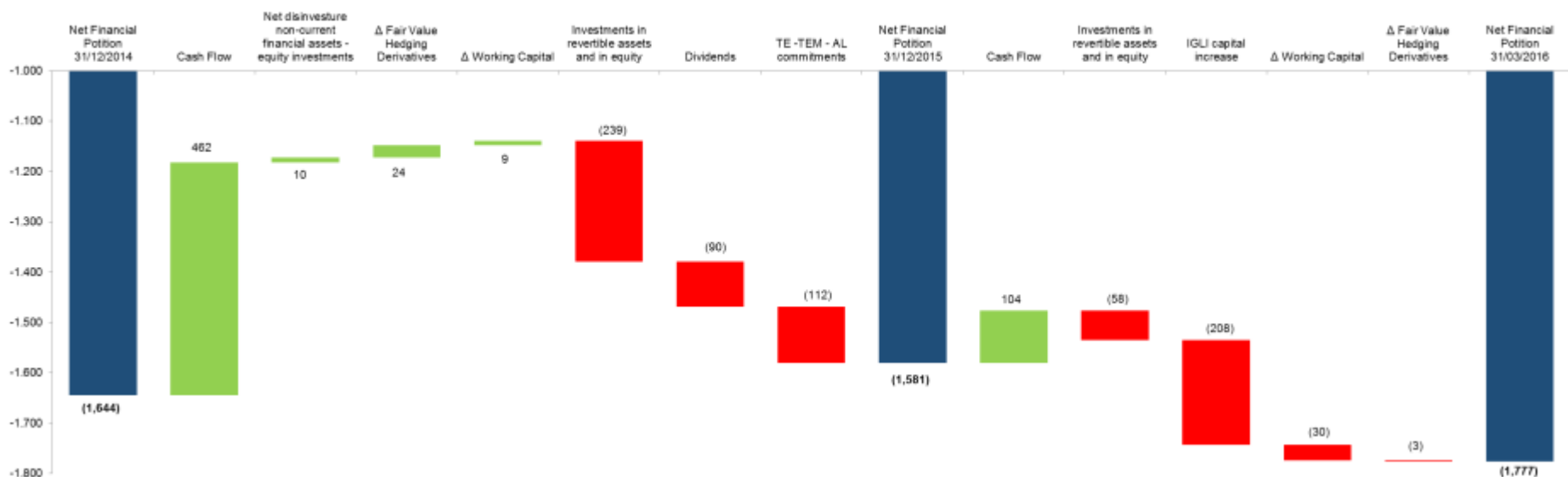



Financial Results

ASTM Group – FY 2015 / Q1 2016 Delivering sound growth

FY 2011 - 2015

(€mln)	2011	(1)(2)2012	2013	2014	2015	CAGR
Turnover	961	940	991	1,041	1,104	2.8%
of which net toll revenues	820	769	857	904	945	2.9%
EBITDA (recurring)	588	539	571	614	646	1.9%
EBIT	336	299	316	325	351	0.9%
Group net profit	104	380	92	100	108	0.8%
Net debt	(1,598)	(1,695)	(1,322)	(1,312)	(1,246)	
Operating cash flow	416	401	400	432	460	
Capex	281	265	283	224	208	
DPS (€)						
- Ordinary	0.41	0.45	0.45	0.45	0.45	
- Extraordinary	-	-	-	-	-	
Pay-out (%)	33%	37%	41%	38%	34%	

2015's results consolidate the growth path of recent years

Q1 2013 – Q1 2016

(€mln)	Q1 2013	Q1 2014	Q1 2015	Q1 2016	CAGR
Revenues	204	224	234	245	6,3%
of which net toll revenues	179	196	201	216	6,5%
EBITDA (recurring)	109	129	133	142	9,2%
Net debt	(1,721)	(1,313)	(1,354)	(1,197)	
Capex	64	47	56	41	

(1) Starting 2012, ATIVA S.p.A. and its Group have been assessed according to the "equity method" (in previous financial years, it was consolidated according to the "proportional method"). In order to provide comparable figures, 2012 figures have been recalculated.

(2) 2012 revenues contains Autostrade Sud America S.r.l. capital gains.

-
- 1 Financial Results
 - 2 **SIAS Group Financial Structure**
 - 3 Operating Activities
 - 4 Regulatory framework
 - 5 Business development
 - 6 Appendix



SIAS Group financial structure

Group's Financial Debt ⁽¹⁾ allocation as of 31 March 2016

SIAS is the **main funding entity** of the Group.

The **proceeds** arising from corporate loans/bond issues are **allocated – through intercompany loans –** to SIAS' operating subsidiaries

A **security interest (pledge) over the intercompany loans is granted** to avoid structural subordination issue.

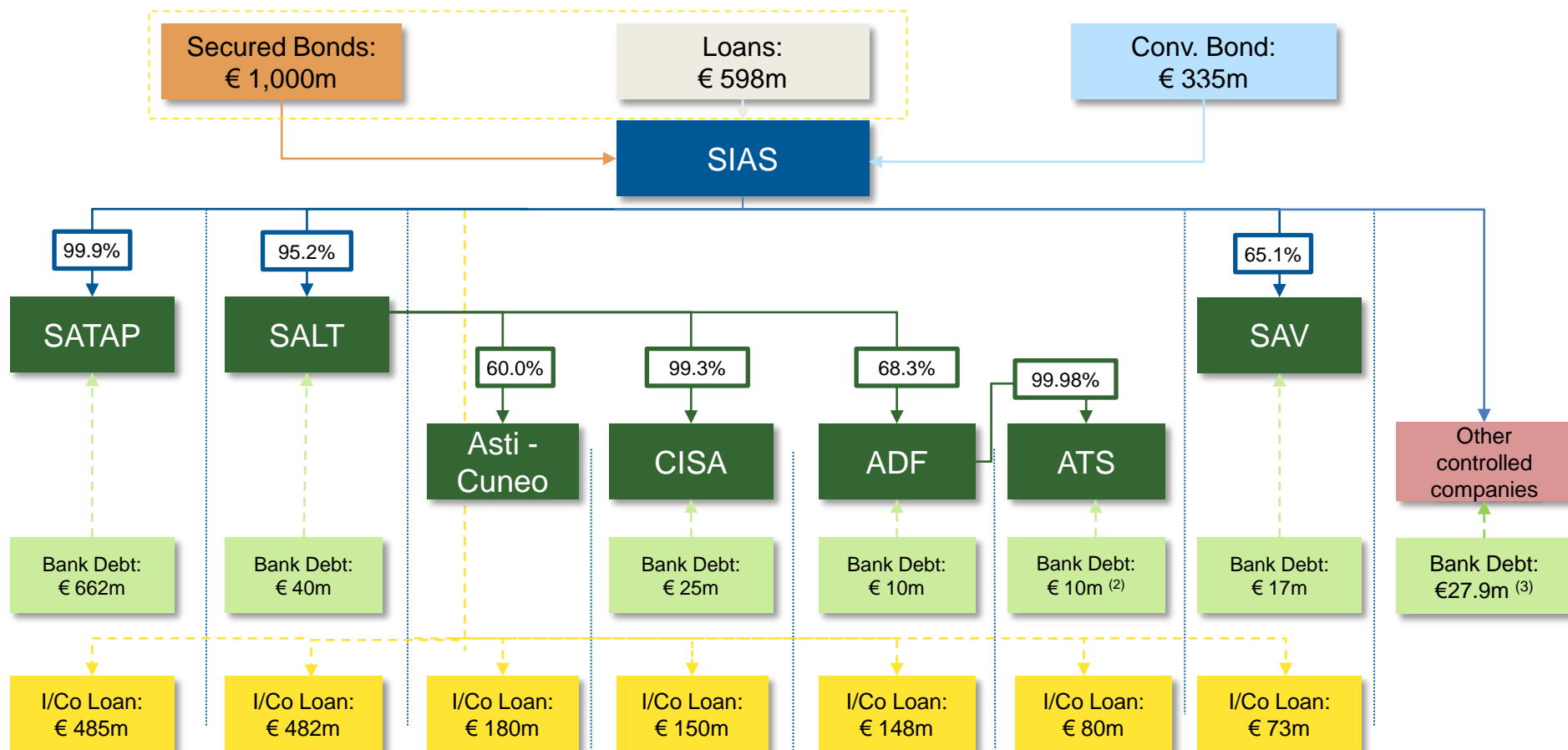

(1) Excluding (i) non financial debt vs. FCG (€ 181.1m), (ii) fair value of derivatives (€ 110.2m) and (iii) bank overdrafts (€ 19.7m).

(2) The repayment is born by ANAS (principal + interest). It is a State contribution granted to ATS to fund some investments and therefore not real debt.

(3) Including Fiera Parking project financing for €26.7m.



SIAS Group financial structure

Group's Financial Debt ⁽¹⁾ details as of 31 March 2016

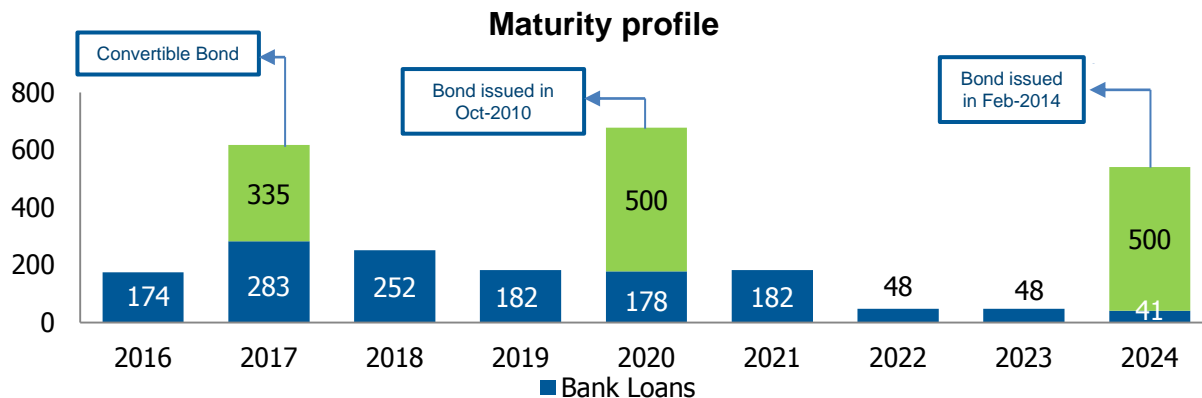

Breakdown by interest rate

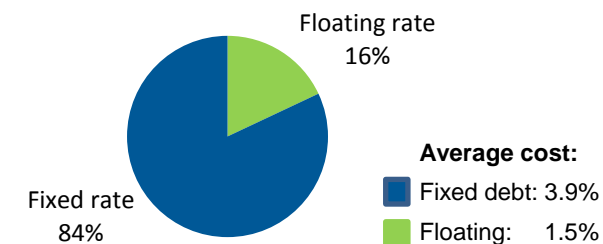

SIAS Group average cost of debt: **3.5%**

Total term financial debt: € 2.7bn with an average maturity of some 4.1 years

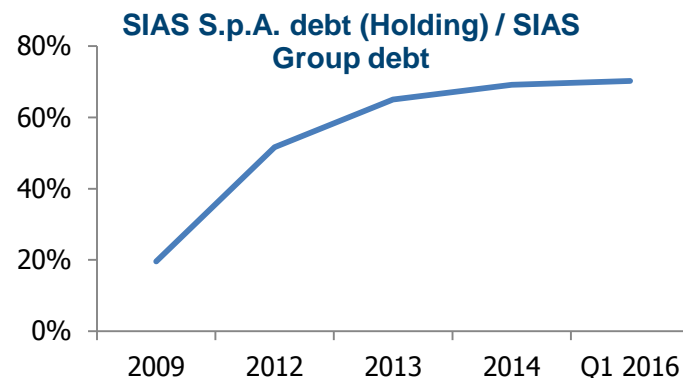
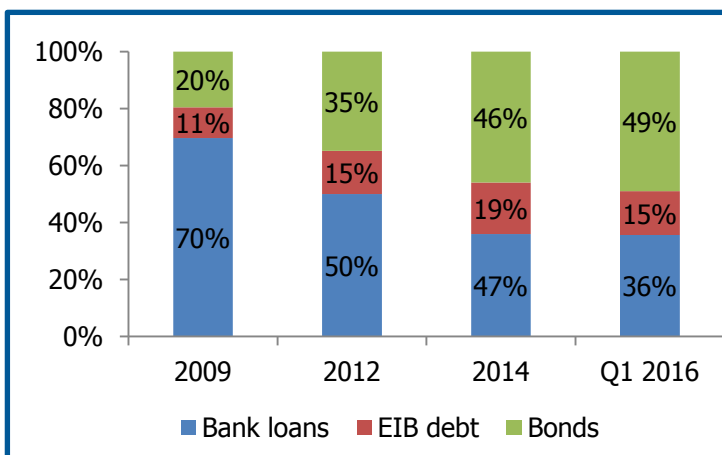

SOLID CREDIT RATING :

- **Baa2 rating** (negative outlook) by **Moody's** (from 2010, confirmed on October 2015)
- **BBB+ rating** (stable outlook) by **Fitch** (from 2014, confirmed on April 2016)

(1) Excluding (i) non financial debt vs. FCG (€ 181.1m), (ii) fair value of derivatives (€ 110.2m) and (iii) bank overdrafts (€ 19.7m).

-
- 1 Financial Results
 - 2 SIAS Group Financial Structure
 - 3 Operating Activities
 - 4 Regulatory framework
 - 5 Business development
 - 6 Appendix



Operating Activities

Traffic performance

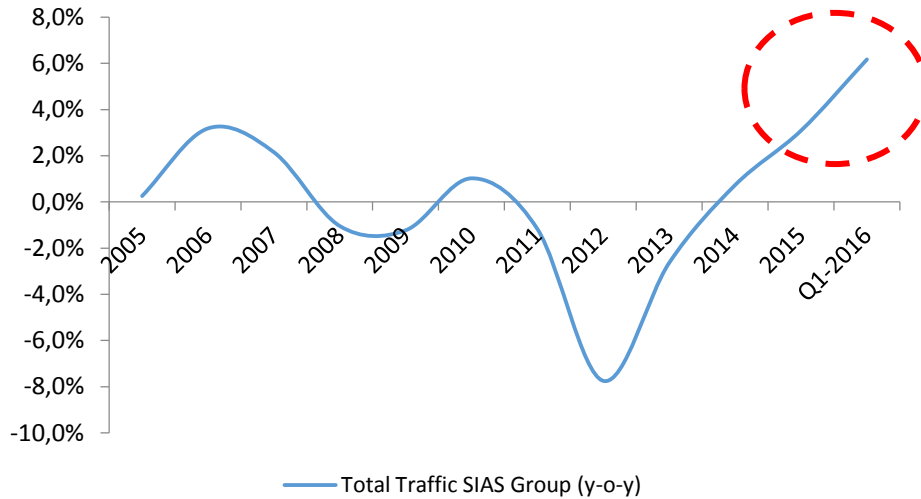

Motorway traffic in 2015 increased by 3.17% and in the first quarter 2016 by 6.19% consolidating the increase consolidated in 2014 and showing a strong and fast ability to recover.

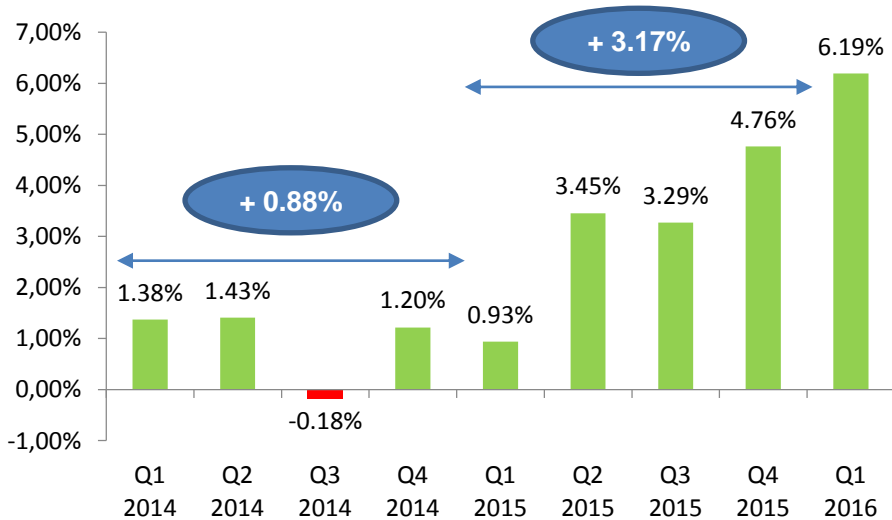



Operating Activities

Traffic performance – cont.

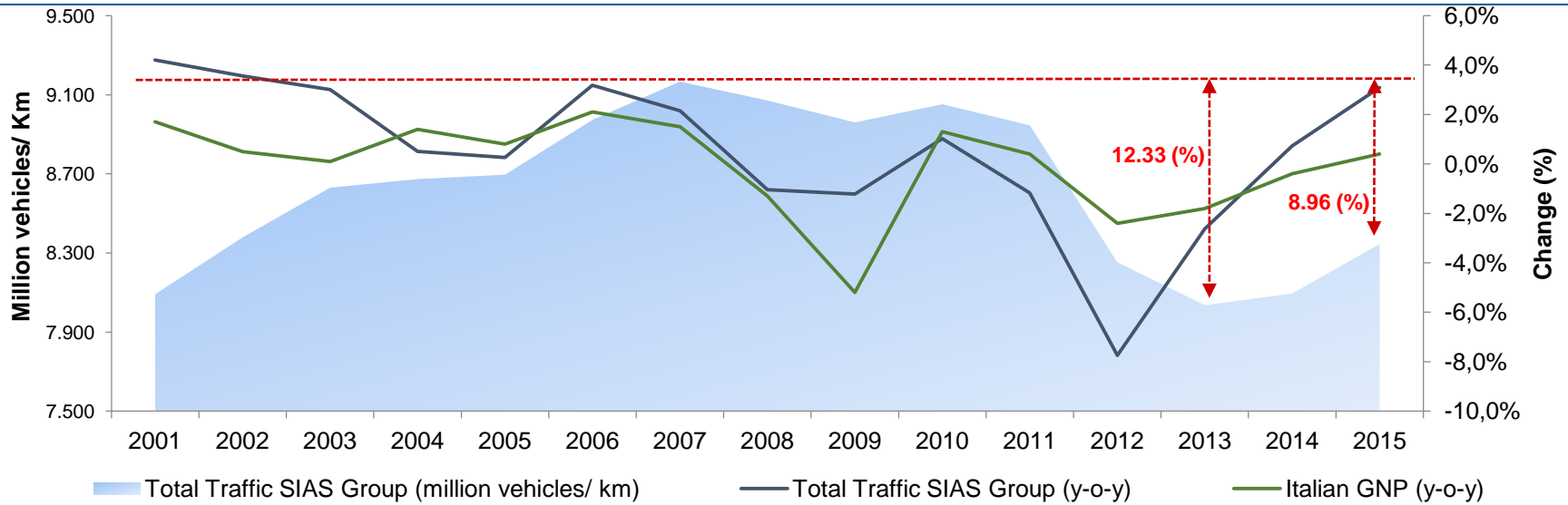

Hp – Traffic increase year on year: +1.3%
 (Q1 +6.19% - others quarters at the same level compared to 2015)

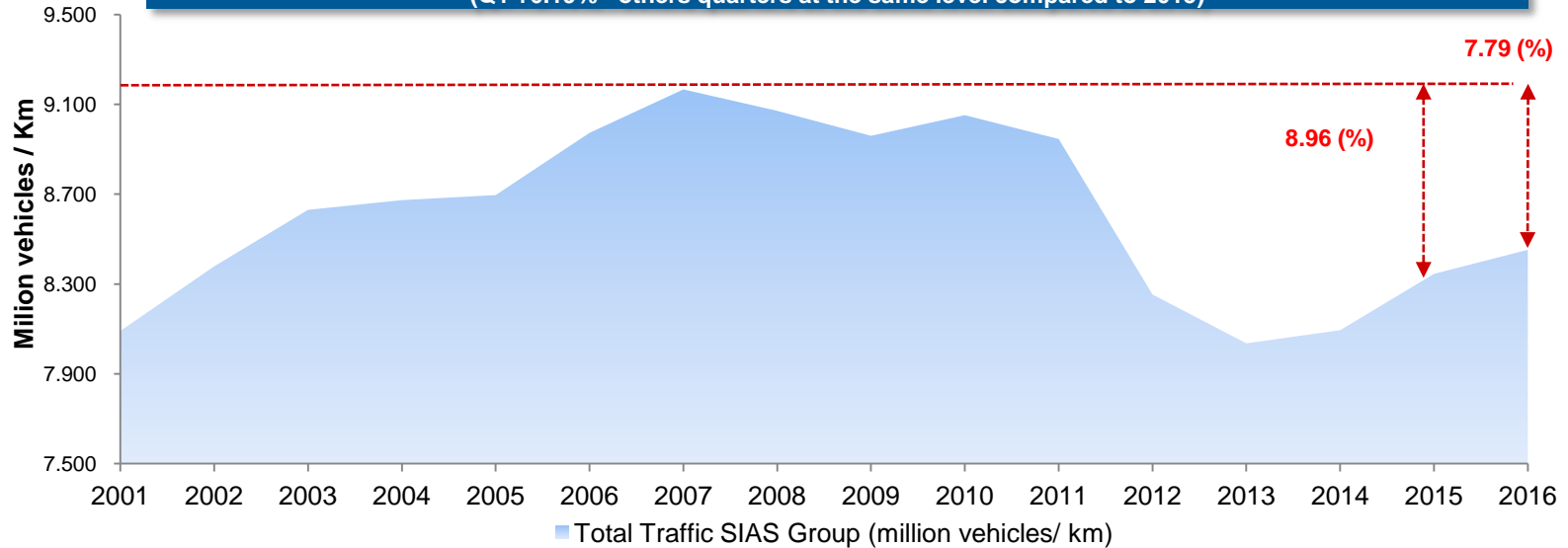



Operating Activities

Traffic performance – cont.

(million vehicles/ Km)	1/1-31/12/2015			1/1-31/12/2014			Change		
	Concessionaries	Light Vehicles	Heavy Vehicles	Total	Light Vehicles	Heavy Vehicles	Total	Light Vehicles	Heavy Vehicles
SATAP S.p.A. – A4 Stretch	1,653	535	2,188	1,589	517	2,106	4.02%	3.47%	3.88%
SATAP S.p.A. – A21 Stretch	1,327	626	1,953	1,290	605	1,895	2.87%	3.54%	3.08%
SAV S.p.A.	268	73	341	255	72	327	5.17%	2.69%	4.62%
Autostrada dei Fiori S.p.A.	956	270	1,226	948	260	1,208	0.84%	4.02%	1.52%
SALT S.p.A.	1,477	357	1,834	1,436	348	1,784	2.84%	2.44%	2.76%
Autocamionale della Cisa S.p.A.	618	185	803	593	182	775	4.22%	1.59%	3.60%
Autostrada Torino-Savona S.p.A.	747	155	902	724	148	872	3.27%	4.50%	3.48%
Autostrada Asti-Cuneo S.p.A.	104	32	136	98	30	128	5.51%	6.06%	5.64%
Total	7,150	2,233	9,383	6,933	2,162	9,095	3.13%	3.31%	3.17%

(million vehicles/ Km)	Q1 2016			Q1 2015			Change		
	Concessionaries	Light Vehicles	Heavy Vehicles	Total	Light Vehicles	Heavy Vehicles	Total	Light Vehicles	Heavy Vehicles
SATAP S.p.A. – A4 Stretch	401	132	533	381	128	509	5.27%	3.27%	4.77%
SATAP S.p.A. – A21 Stretch	295	152	447	276	147	423	6.66%	3.13%	5.43%
SAV S.p.A.	69	17	86	62	17	79	12.19%	2.28%	10.04%
Autostrada dei Fiori S.p.A.	188	65	253	176	63	239	6.99%	4.33%	6.29%
SALT S.p.A.	292	81	373	270	79	349	8.08%	2.33%	6.78%
Autocamionale della Cisa S.p.A.	106	41	147	94	41	135	12.32%	1.12%	8.94%
Autostrada Torino-Savona S.p.A.	153	37	190	142	34	176	7.91%	3.27%	6.98%
Autostrada Asti-Cuneo S.p.A.	24	8	32	22	7	29	5.99%	7.35%	6.32%
Total	1,528	533	2,061	1,423	516	1,939	7.33%	3.07%	6.19%

Leap year effect	(1.15%)
Adjusted Traffic increase	5.04%



Operating Activities

SIAS Group – FY 2015/Q1 2016 CAPEX

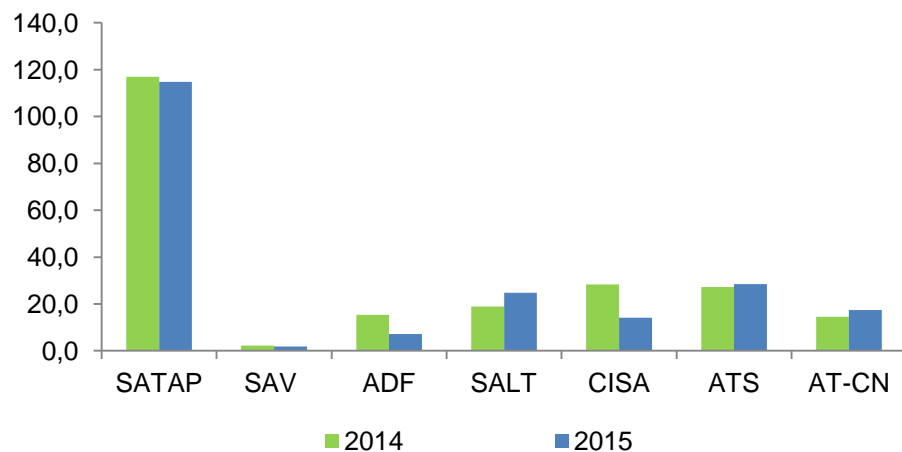

(€mln)	2015	2014
SATAP	114.7	116.9
SAV	1.8	2.3
ADF	7.1	15.3
SALT	24.8	18.9
CISA	14.1	28.3
ATS	28.5	27.3
AT-CN	17.4	14.6
Total	208.4	223.6

(€mln)	Q1 2016	Q1 2015
SATAP A4	25.0	39.3
SAV	0.9	0.3
ADF	2.2	1.4
SALT	3.8	4.2
CISA	1.8	3.5
ATS	4.0	4.7
AT-CN	3.3	2.4
Total	41.0	55.8

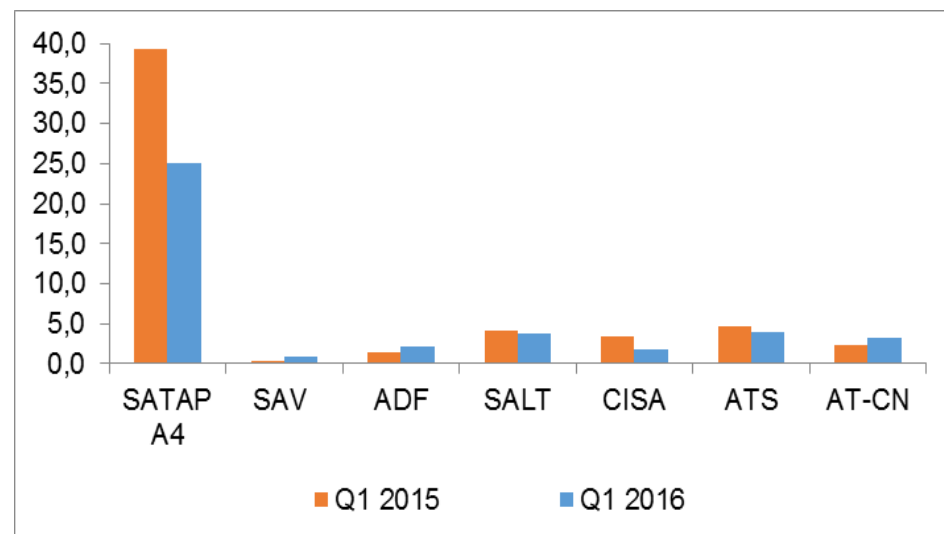

Operating Activities

SIAS Group – Capex plan

Total CAPEX: € 1.2 mld

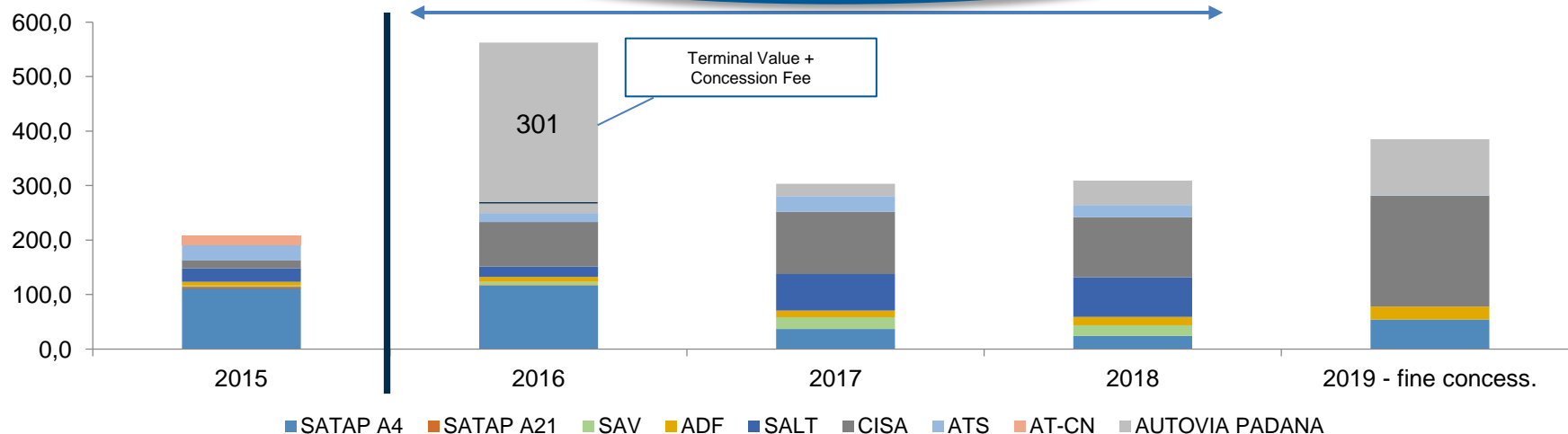

(€mln)	2016	2017	2018	2019 – expiry of the concession
SATAP A4	116.3	36.9	24.5	54.4
SATAP A21	1.1			
SAV	6.2	21.6	19.2	
ADF	8.9	12.0	15.2	23.7
SALT	19.0	67.3	72.7	
CISA	81.7	114.4	110.6	203.3
ATS	16.3	28.4	22.1	1.0
AT-CN				
AUTOVIA PADANA	312.6 ⁽¹⁾	23.0	44.8	102.6
Totale	562.3	303.5	309.1	385.0

(1) Terminal Value € 260 mln + Concession Fee € 41 mln + CAPEX (lotto 1) € 1.6 mln

-
- 1 Financial Results
 - 2 SIAS Group Financial Structure
 - 3 Operating Activities
 - 4 Regulatory framework
 - 5 Business development
 - 6 Appendix



Regulatory Framework

Key dates

August 2014	<p>Italian Government filed a plan with the competent EU Authorities aimed at supporting compensation measures against an infrastructure investment programme involving the licensees of the SIAS Group.</p> <p>The plan set out the consolidation of concession relations, the concession expiry in 2043, the control of tariffs (1.5% per year) and an investment plan equal to approximately EUR 7 billion (increase of € 5.2 billion compared to original plans.).</p>
30/12/2014	<p>SIAS Group concessionaries signed a specific "memorandums of understanding" with the MIT, according to which a toll increase equal to 1.5% will be applied for 2015, and if the implementation agreement of the "aggregate" Plan was not signed and approved by 30 June 2015, the updates of the financial plans of each "single" Group licensee would need to be approved by the same date and, as a consequence and as part of the said updates, lower revenues achieved in 2015 (due to the lower toll increase applied) would be recovered, with no change in the financial effects.</p>
30/06/2015	<p>Original due date for:</p> <ul style="list-style-type: none"> - the signing of the agreement implementing the Plan submitted by the Italian Government at EU level (and in compliance with the documents submitted by the SIAS Group on 31 December 2014), or - the approval of the updates of the single Economic Financial Plans for the regulatory period 2014 2018.
June 2015	SAV, ADF, ATS, CISA, SALT submitted, after MIT's request, an update of the single Economic Financial Plans for the regulatory period 2014 2018.
October 2015	Formal request to MIT to immediately approve, in any event no later than 15 October 2015, the pending financial plans.
15/10/2015	Formal request of toll increase sent for FY 2016
31/12/2015	<p>Toll increase approved from 1 January 2016: SATAP - Turin Milan stretch (+6,50%), ATIVA (+0,03%) e TE (+2,10%)</p> <p>For all other motorway stretches managed by subsidiaries the toll adjustments were provisionally suspended considering that the related Economic Financial Plans are currently in the inquiry phase with the competent Ministries.</p>
01/02/2016	Due date for the submission of the Economic Financial Plans from MIT to CIPE
29/02/2016	Appeals were lodged with the Regional Administrative Court over the MIT's decisions of (i) toll increase suspension and (ii) SATAP -Turin Milan stretch toll increase

LAST EVOLUTION **Interlocutions with MIT and with the EU in order to find a solution and an economic and financial balance for the financial plans based on extensions in line with the French model and framework.**

Recently CIPE gave the greenlight – with some provisions – to MIT in order to release the approval on the SATAP A-21, ADF, SALT, SAV, ATS and SITAF Financial Plans. The Group is waiting for the full disclosure of the CIPE deliberation and to be summoned at MIT for the negotiation and signing of the formal amendments.



Regulatory Framework

Tariff increase and next key dates

2016 EVOLUTION

Based on that set out in the Interministerial Decrees issued on **31 December 2015** by the Ministry of Infrastructure and Transport ("MIT") in concert with the Ministry of Economy and Finance ("MEF"), from 1 January 2016 **the following toll increases were approved for the licensees that the SIAS Group holds investments in and, specifically:**

- +6.50% for SATAP S.p.A. (A4 Turin-Milan stretch);
- +0.03% for ATIVA S.p.A.;
- +2.10% for Tangenziale Esterna S.p.A.

For all other motorway stretches managed by subsidiaries (including jointly controlled companies) in the SIAS Group – and, in particular, by SATAP S.p.A. (A21 Turin-Piacenza stretch), by Autostrada Torino-Savona S.p.A. (A6), by Autostrada dei Fiori S.p.A. (A10), by SALT S.p.A. (A12), by Autocamionale della Cisa S.p.A. (A15), by SAV S.p.A. (A5) and Società di Progetto Bre.Be.Mi S.p.A. (A35) – the toll adjustments were provisionally suspended considering that the related Economic-Financial Plans are currently in the inquiry phase with the competent Ministries.

In this regard, according to the related Interministerial Decrees (i) the MIT will request that the proposed Economic-Financial Plans formulated by the aforementioned licensees be registered with the CIPE **by 1 February 2016** for the related opinion, (ii) the final toll adjustment for 2016 will be determined through Interministerial Decrees approving the Economic-Financial Plans and will be immediately applicable, and (iii) the recovery of the toll adjustment for the period of suspension from 1 January 2016 to the issue date of the Decrees approving the Economic-Financial Plans will be recognised on approval of the toll adjustment for 2017.



Regulatory Framework

Tariff increase and next key dates

All concessionaires, in the meantime, to protect its rights have undertaken the most appropriate forms of appeal against both the suspension of tariff adjustments required caused by the delay in the new Financial Plans (not depending on the concessionaries themselves) both, regarding SATAP S.p.A. - A4 Turin-Milan, the size of the increase granted.

The concessionaire SATAP S.p.A. A21 - Torino-Piacenza, even before the year-end rates decrees, appealed to the Lazio Regional Administrative Court against the silence of the government because, two years after the expiry of the five years regulatory plan, has not yet approved the new Financial Plan.

As concerns Autostrada Asti-Cuneo, an appeal was lodged with the Regional Administrative Court over the MIT's failure to approve the executive plan for the Verduno tunnel. At the same time, negotiations continued with the MIT in an effort to identify solutions to ensure operation of the stretch of motorway, within the limits of the Economic-Financial Plan.

Interlocutions with MIT and with the EU in order to find a solution and an economic and financial balance for the financial plans based on extensions in line with the French model and framework.

-
- 1 Financial Results
 - 2 SIAS Group Financial Structure
 - 3 Operating Activities
 - 4 Regulatory framework
 - 5 Business development
 - 6 Appendix



Business Development

Acquisition of joint control of Ecorodovias

On **4 May 2016** ASTM and SIAS **closed the transaction** with CR Almeida S.A. Engenharia e Construcões for the acquisition by IGLI of joint control, together with Primav Construcões e Comercio S.A., of the Brazilian law spv Primav Infraestrutura S.A. which holds (i) **64%** of capital stock of **Ecorodovias Infraestrutura e Logística S.A.**, (ii) **55%** of the capital stock of **VEM ABC** (iii) as well as a debt of approximately R \$ 878 million. The deal was closed after obtaining the permission of government authorities and both Primav both Ecorodovias' lending banks consent. **By virtue of the agreements reached between the parties, the original investment for the capital increase subscribed by Igli, was reduced by 120 million reais.**

By completing such transaction ASTM and SIAS now manage a **portfolio of toll road concessions of around 3,320 km (1,462 in Italy and 1,858 in Brazil)** in prosperous and highly industrialized areas, thus becoming the **fourth largest player among European and South American motorways operators** and materially increasing their capability to take part to international tenders.

The transaction represents a significant step in the **process of growth and geographical diversification** undertaken by ASTM and SIAS fostering the implementation of the Group strategy of joint development of concession and construction businesses.

Ecorodovias assets are located in the highest populated and richest areas of Brazil. Toll roads will benefit from **favorable traffic dynamics** (historical traffic growth well above GDP and low car ownership) coupled with a **stable and flexible regulatory framework** (potential contractual amendments, i.e. extension of concessions duration in exchange of additional capex).



Primav Infraestrutura S.A. and Ecorodovias S.A. Share Capital

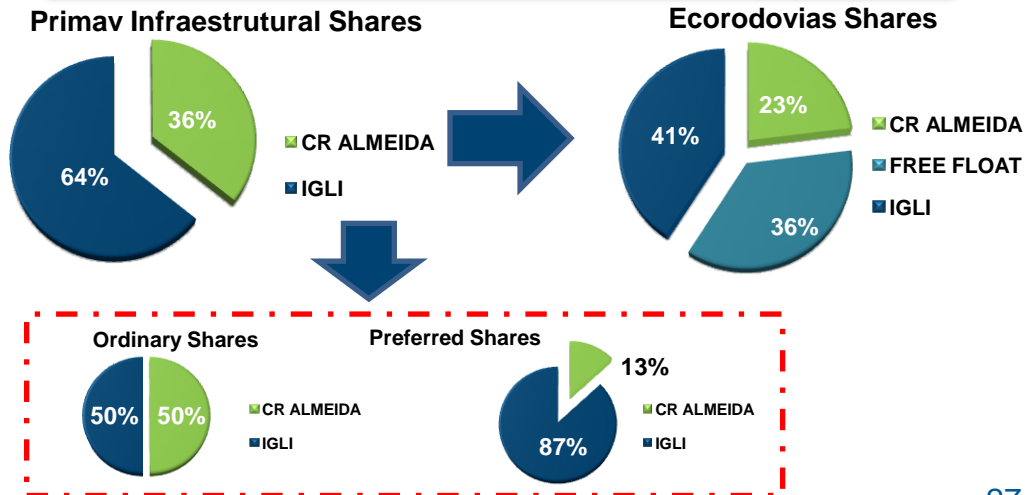



Business Development

Acquisition of joint control of Ecorodovias

The transaction will turn Gavio Group into the fourth biggest player among European and South American motorway operators

Top motorway networks under concession of European origin (in km)

After Ecorodovias acquisition

December 2015³

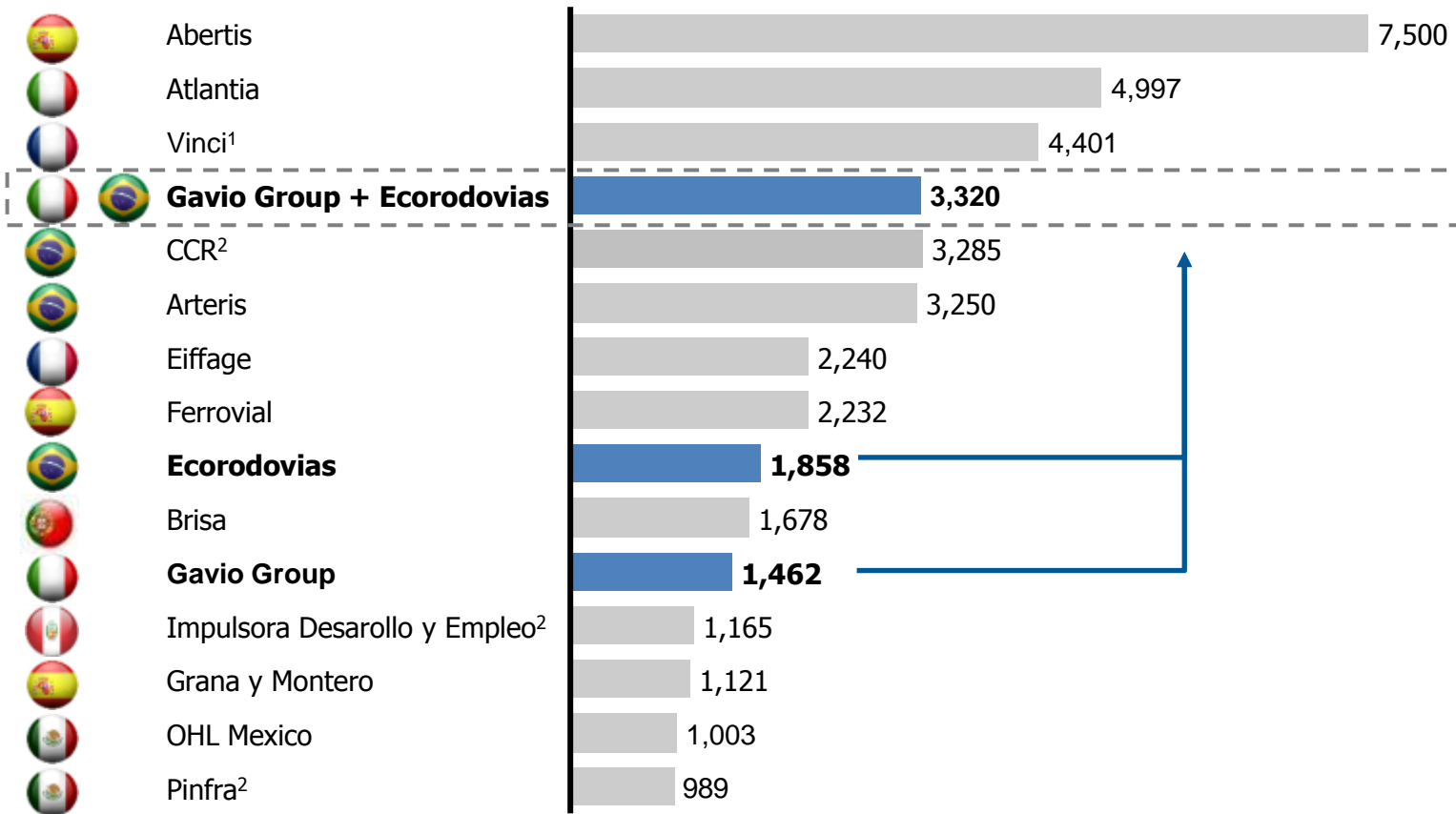

¹ Vinci Autoroutes includes: ASF, Cofiroute, Escota, Arcour; ² 2014 data

SOURCE: Bloomberg; Company presentations; McKinsey Research



Business Development

Acquisition of joint control of Ecorodovias

Pre-deal

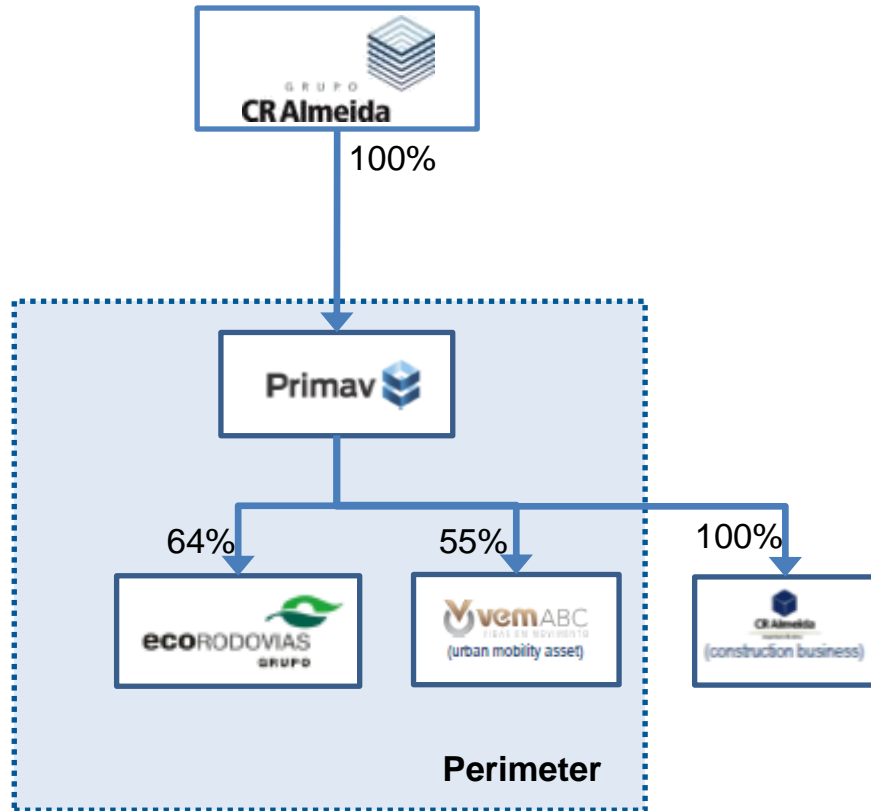

Post-deal

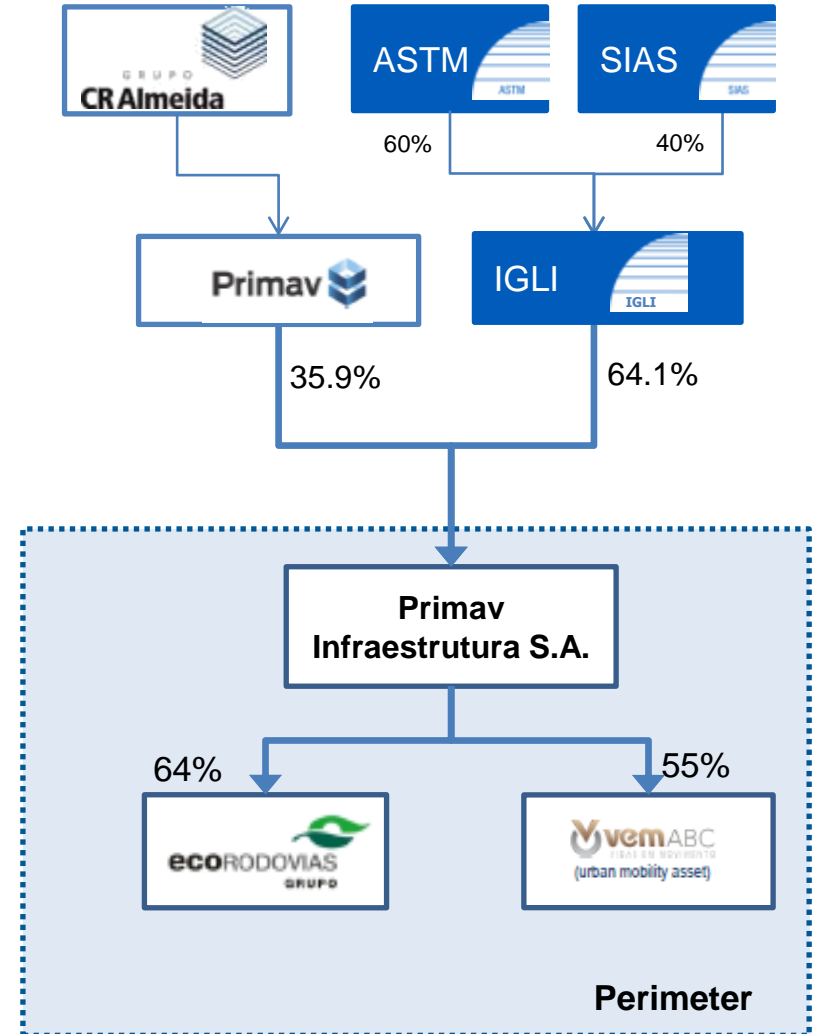



Business Development

Price adjustment and main changes pre/post closing

SIGNING 18/12/2015

Primav Infraestrutura S.A. Share Capital divided into ordinary shares (72%) and preferred shares, without voting right (28%)

Ordinary Shares owned by IGLI S.p.A (50%) and by CR Almeida (50%)

Preferred Shares entirely owned by IGLI S.p.A.

Share Capital Increase in PRIMAV to be subscribed by IGLI S.p.A. for BRL 2,224 million (€ 529 million)

EcoRodovias S.A. equity value

Price/Share: 5,40 €

Market Cap: BRL 3,017 million (€ 757 million – exchange rate as at 18/12/2015)

CLOSING 04/05/2016

Primav Infraestrutura S.A. Share Capital divided into ordinary shares (62%) and preferred shares, without voting right (38%)

Ordinary Shares owned by IGLI S.p.A (50%) and by CR Almeida (50%)

Preferred Shares owned by IGLI S.p.A. (87%) and by CR Almeida (13%)

Share Capital Increase in PRIMAV subscribed by IGLI S.p.A. for BRL 2,104 million (€476 million)

Price adjustment for BRL 120 milioni (€ 27 million)

Loan from IGLI to Primav Construcoes e Comercio S.A. for an amount of BRL 120 million (interest rate based on CDI) guaranteed by a pledge over preferred shares owned by CR Almeida (13%). The amortisation of this loan will start from 2018 with annual payments during the next 5 years

EcoRodovias S.A. equity value

Price/Share: 7,67 €

Market Cap: BRL 4,285 million (€ 1,074 million – exchange rate as at 04/05/2016)

EcoRodovias Infraestrutura e Logistica S.A. (ECOR3.SA) - Sao Paolo Codice: RACNOR/SIN: BRECORACNOR8

8,79 (closing price as at 5th September 2016)

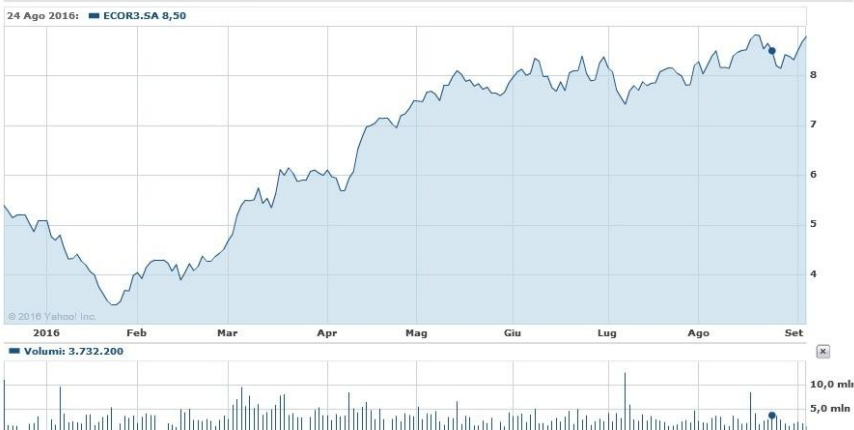

EUR/BRL (EURBRL=X) - CCY

3,6500 (closing exchange rate as at 5th September 2016)





Business Development

EcoRodovias' Geographic Footprint

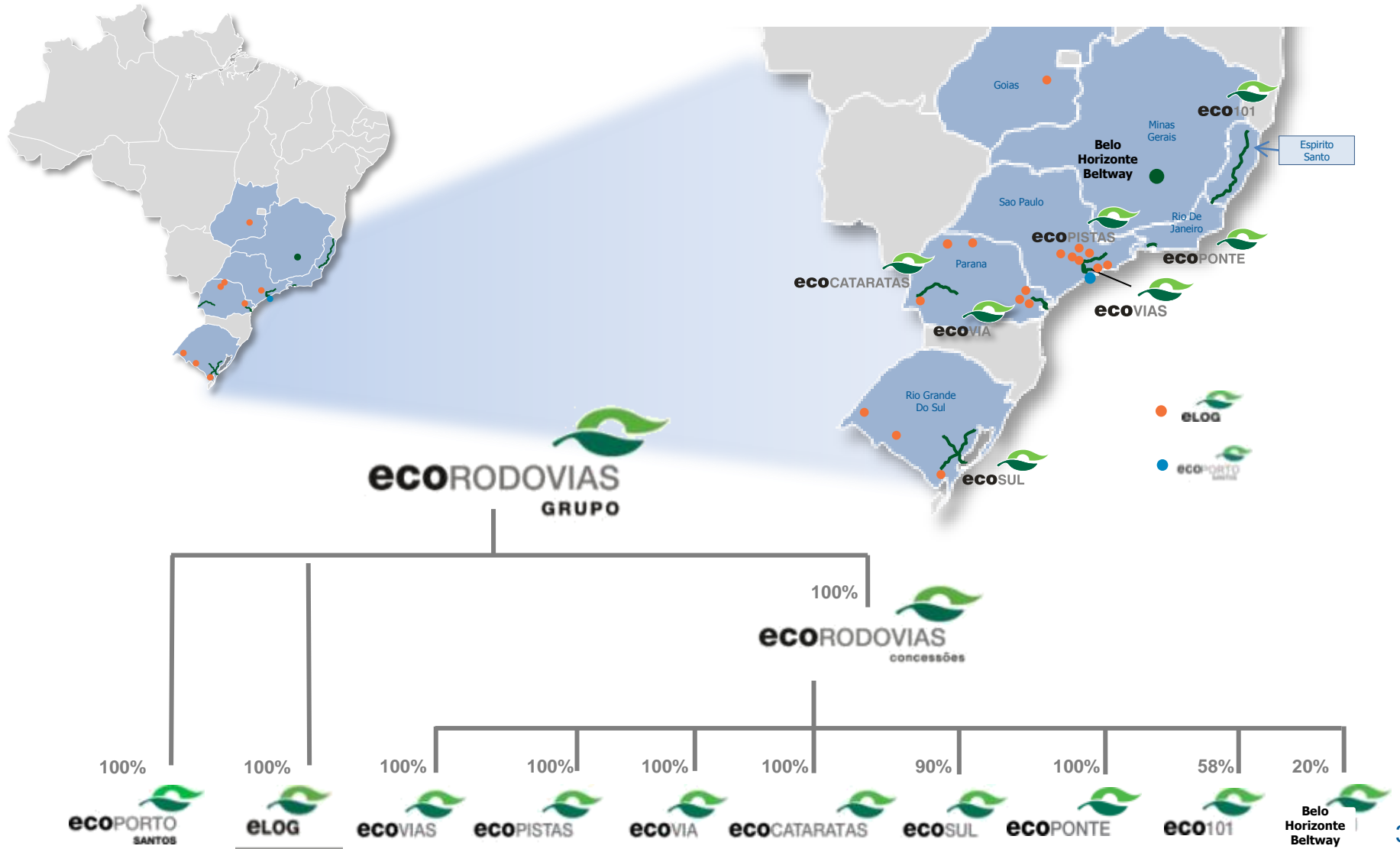



Business Development

EcoRodovias' assets

Diversified portfolio of assets with long remaining duration: 17 years and 2 months without taking into consideration potential extensions

EcoRodovias Group - Concessionaries

Concessionaires	Stake (%)	Km	Expiry	Remaining duration	State	EBITDA '15 R\$ million	EBITDA margin	EBITDA '14 R\$ million	EBITDA margin	2015/2016 Tariff adj.	Last Tariff adj.
Ecovias dos Imigrantes	100%	177	Oct-25	9.1	SP	676	78.1%	639	77,6%	4.1%	Jun-15
Ecopistas	100%	135	Jun-39	22.1	SP	150	61.0%	139	59,6%	8.5%	Jun-15
Ecovia Comiho do Mar	100%	137	nov-21	5.2	PR	152	70.5%	137	66,8%	7.2%	Dec-15
Ecocataratas	100%	387	nov-21	5.2	PR	165	65.8%	164	65,7%	9.4%	Dec-15
Ecosul	90%	457	mar-26	9.7	RS	119	65.0%	114	68,1%	36.2%	Jan-16
ECO101	58%	476	May-38	21.9	ES	73	42.1%	17	16,1%	18.6%	May-15
Ecoponte	100%	23	May-45	28.9	RJ	30	51.1%			12.3%	Jun-15
Belo Horizonte Beltway	20%	66	Dec-46	31	MG	N/A	N/A	N/A	N/A	N/A	N/A
Total		1,858		16y 8m		1,365	68.5%	1,210	67.9%		



Business Development

EcoRodovias – Financials

- Amongst the highest profitability of toll roads in the sector
- Leverage broadly in line with SIAS Group

(€mln) ⁽¹⁾	2013	2014	2015	H1 2015	H1 2016 ⁽²⁾
Comparable Pro-Forma Net Revenues	649	669	705	308	320
Comparable Pro-Forma EBITDA	343	352	390	183	207
<i>Comparable Pro-Forma EBITDA margin</i>	53%	53%	55%	59%	65%
<i>Toll roads EBITDA margin</i>	70%	68%	69%	69%	71%
Comparable Net Income	103	71	30	18	31
Pro-Forma Capex	225	284	195	87	63
Pro-Forma Net Debt	734	1,022	1,221	1,106	1,110
Net Debt/EBITDA - LTM	2.0x	2.4x	3.1x	3.1x	2.7x

(1) Exchange rate as at 05/09/2016 (3.6500 €/R\$)

(2) Excludes construction revenue and costs, provisions for maintenance, assets held for sale (Elog), non recurring items and non cash caused by the Ecoporto impairment (R\$301 million)



Business Development

EcoRodovias – Traffic performance

Traffic impacted by the negative performance of the economy and adverse weather conditions

Traffic Volume (equivalent paying vehicles x million)

CAGR12-15: +12.0%

Comparable Traffic Volume¹(equivalent paying vehicles x million)

CAGR12-15: +2.8%

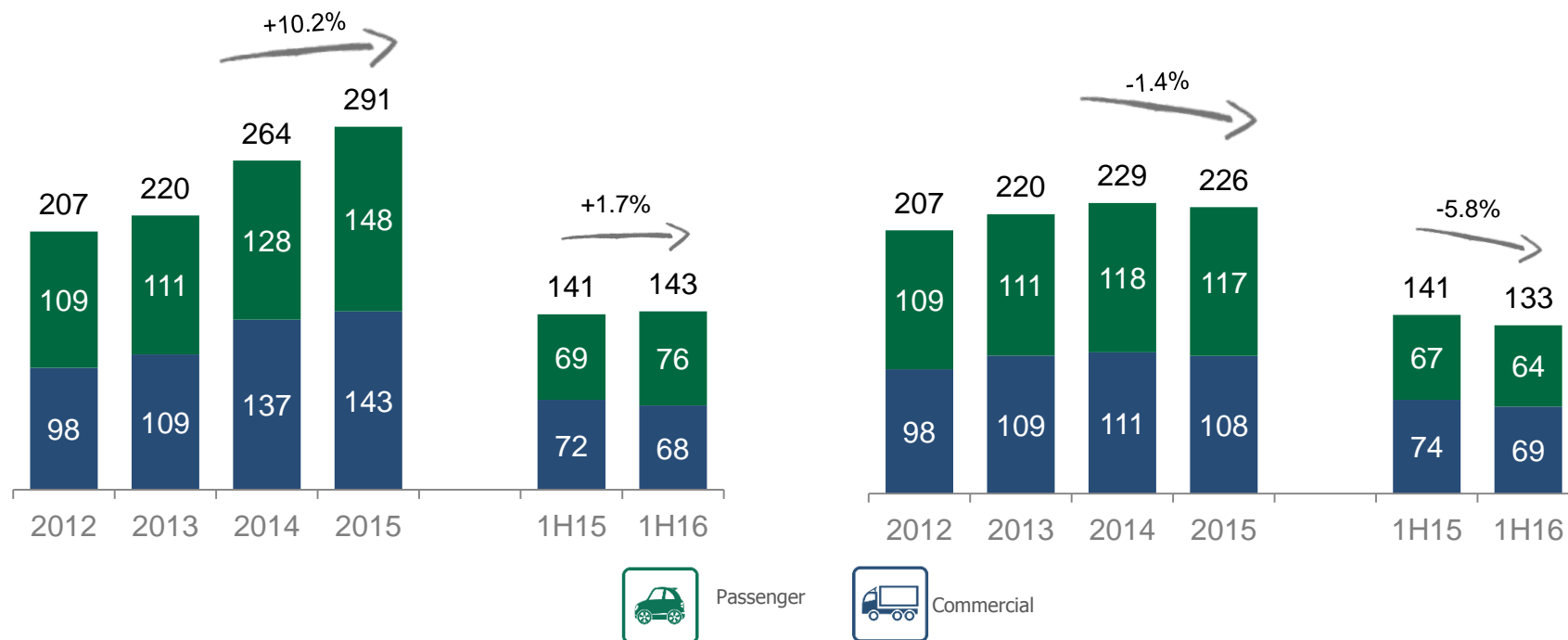

¹ Excludes the impact from the exemption of tolls for suspended axles; for 2014 and 2015, excludes traffic at ECO101 and Ecofonte; for 1H15 and 1H16, excludes traffic at Ecofonte



Business Development

EcoRodovias – Financials

Net Revenue (R\$ million)

CAGR12-15: +11.6%

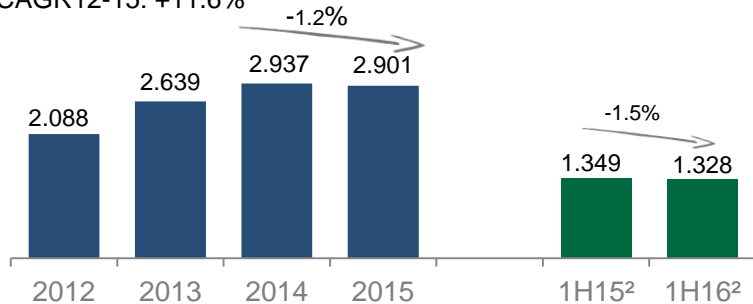

Pro Forma - Net Revenue (R\$ million)

CAGR12-15: +7.9%

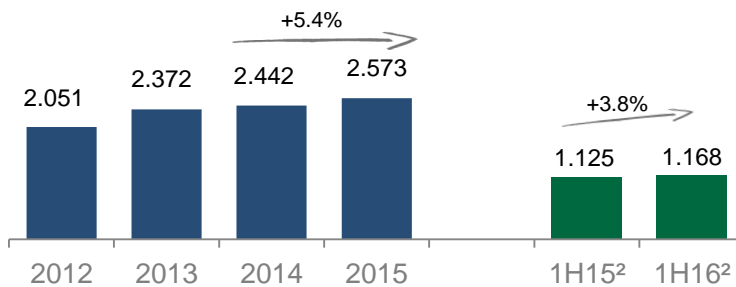

¹ Excludes construction revenue and revenue for STP, for 2012 to 2015 considers 80% of Elog until June, 30, 2015, and 100% since July 1, 2015.

² For 1H15 and 1H16: Assets held for sale (Elog) aren't consolidated.

Comparable Pro-forma EBITDA¹ (R\$ million and %)

CAGR12-15: +6.6%

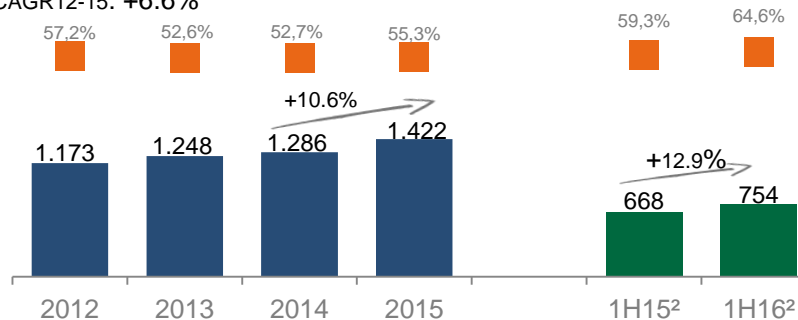

Comparable Pro-Forma Cash Cost (R\$ million)¹

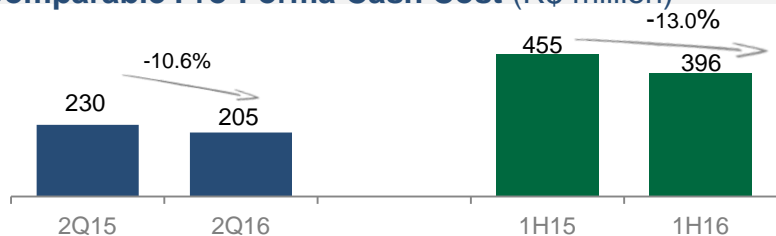

Comparable Net Income¹ (R\$ million)

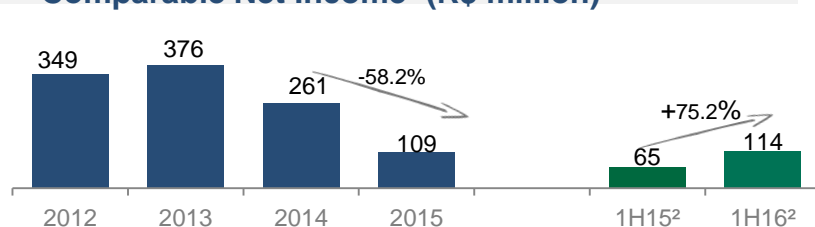

¹ Don't consolidate costs and expenses from assets held for sale (Elog), excludes depreciation and amortization, construction costs, provision for maintenance, cash costs at Ecofonte.



Business Development

EcoRodovias – Strategy

Short term – 1 year

- ✓ Negotiate contractual amendments
- ✓ Focus on reducing costs & Capex optimization
- ✓ Divestment of Elog

Medium term – 3 years

- ✓ Deleveraging
- ✓ Divestment of Ecoporto
- ✓ Explore the potential of contractual amendments
- ✓ Participation in public bids for toll road according to financial capacity
- ✓ Opportunities in secondary market

Long term – 5 years

- ✓ Capture profitable growth with the new round of privatization of toll road concessions
- ✓ Explore contractual amendments
- ✓ Opportunities in secondary market





Business Development

EcoRodovias – Value Creation through Amendments in Existing Contracts

EcoRodovias has already mapped several value creation opportunities within the existing portfolio through contract amendments

Overview of Contract Amendments Under Discussion with Granting Authorities

Key Rationale for Contract Amendments

- Significant value creation for the concessionaire, and opportunity to make viable, important improvements for users and Granting Authority
- Solution for current or future capacity bottlenecks in a scenario with high pressure for infrastructure development
- New investments compensated by concession extension and / or tariff increase
- Attractive returns given the lower risk profile of new investments
- Reinvestment in already known assets with mitigated risks

Risks	Mitigation
Traffic	• No risk. Traffic variations are subject to new contract rebalances
CAPEX	• Ability to develop a detailed engineering project for an asset already known
OPEX	• Low additional OPEX, considering the asset is already operational and there are economies of scale

Note: (1) Three-year validity from 21-out-2015 for federal and Paraná state concessions.
SP state concessions usually use a negotiated marginal cash flow IRR

Examples of Projects Already Under Analysis



- Santos *Binário*



- Access to Port and others



- Duplication of BR-277



- Duplication and others

Current Project IRR (real terms, unlevered)⁽¹⁾

Stage	IRR	Toll Roads
1 st Stage	9.43%	Ecoponte and ECO-101
2 nd Stage	9.77%	n.a.
3 rd Stage	9.95%	Ecovia, Ecocataratas and Ecosul
SP State	~9.8%	Ecovias and Ecopistas



Business Development

EcoRodovias – Financial Performance Non-recurring and non-cash effects

- ✓ **Elog:** recognized under assets and liabilities from discontinued operations held for sale, given the expectation of the sale occurring within 12 months.
- ✓ **Ecoporto:** write-off of impairment and deferred taxes, given the recession and the intense competition, which led to a drop-off in operating volumes at this services.

These accounting practices will: (i) the lower future amortization of goodwill from the acquisition of Ecoporto due to the impairment test conducted; (ii) allow the recording of tax credits arising from possible future economic losses at Ecoporto Santos; (iii) the absence of any impact of the discontinued operations, if the amount expected from the sale of Elog S.A. and Ecopátio Cubatão is maintained.; and (iv) not affect the Company's future capacity to participate in auctions of highway concessions, while always adopting capital discipline and considering its financial capacity and the return from each project.

- ✓ **Capital reduction to absorb accumulated losses.**

The reduction would generate benefits for shareholders: enabling the future payment of dividends from the profits earned in subsequent periods, always in keeping with the strategy of maximizing value for shareholders.



Business Development

VEM

Shareholdings

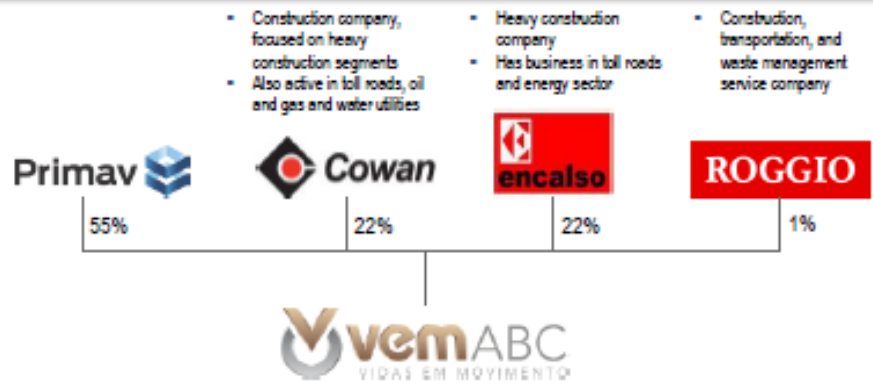

VEM ABC
is a greenfield project to build and operate a 14.9-km monorail system linking the São Paulo rail network with the ABC region

Object	Construction, concession and operation of 14.9 km monorail in São Paulo metropolitan region with 13 stations
Demand	443 thousand passengers per day
Implementation deadline	4 years
Concession model	PPP (sponsored concession) with minimum level of revenues guaranteed.
Contract signing date	August 22, 2014
Contract starting date	2017
Term	25 years
Total CAPEX	6bn R\$ of which 3bnR\$ of public grants
PPP structure	Government subvention for CAPEX and pecuniary consideration paid by the government to the consortium
Operating starting date	Expected for 1H-2019





Business Development

Itinera - Reallocation of the Construction Business

On **28 April 2016** ASTM's General Meeting of Shareholders approved an increase in the share capital of ASTM S.p.A. that finalize the **transfer of the controlling interest in Itinera (construction sector) to ASTM**.⁽¹⁾

Before ASTM Share Capital Increase

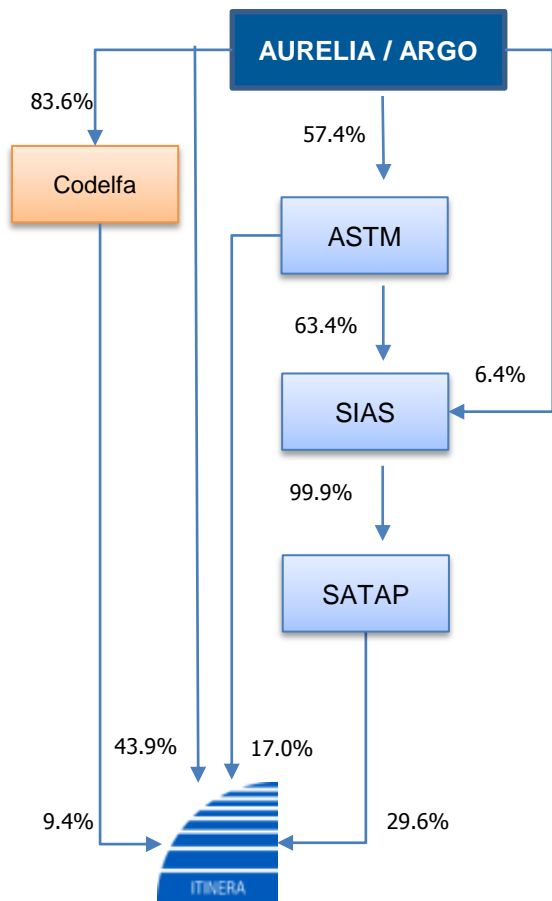

After ASTM Share Capital Increase

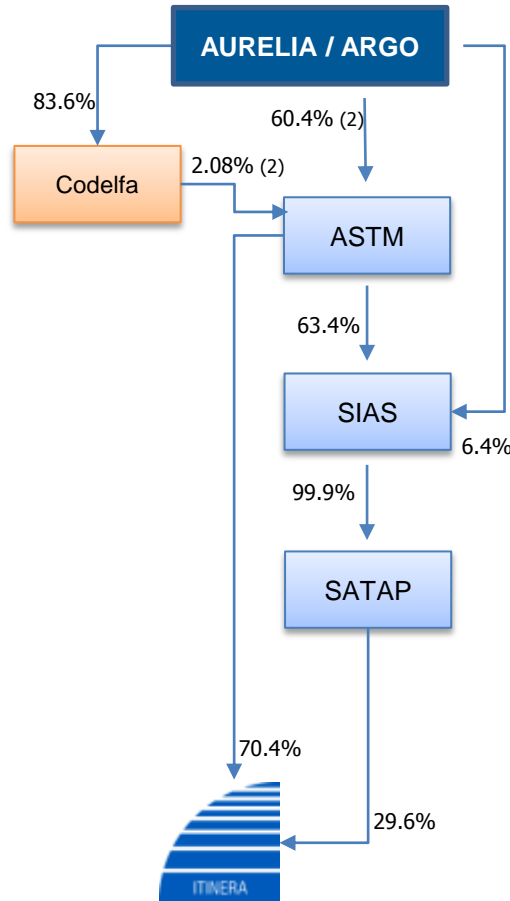

The contribution strengthens the **strategic focus on developing the greenfield concessions business** and will enable fuller exploitation of all opportunities that could arise in **domestic and international market**, especially in South America, in light of recent agreements with CR Almeida as part of the Ecorodovias deal.

(1) The transfer will be effective from 1st July 2016

(2) Net of Treasury Shares as at 5th June 2016



Business Development

Itinera – Consolidated Financials

(€mln)	2014	2015
Revenues	1,012.4	771.0
Operating Costs	(945.6)	(727.5)
EBITDA	66.8	43.5
<i>EBITDA (%)</i>	6.60%	5.64%
EBIT	48.5	24.5
<i>EBIT (%)</i>	4.79%	3.18%
Financial management results	0.9	(5.8)
Earnings before taxes	49.4	18.7
Taxes	(16.2)	(7.7)
Consolidated results	33.2	11.0
Results pertaining to minority shareholders	(0,0)	(0,0)
Group results	33.2	11.1

Consolidated Revenues

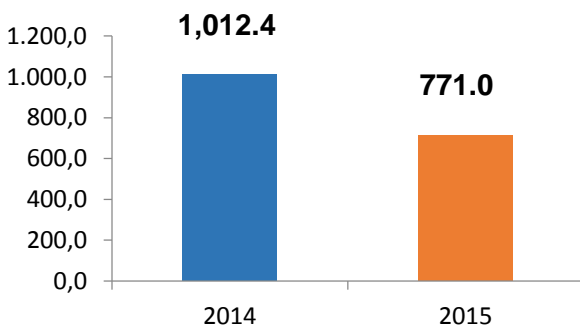

Consolidated EBITDA

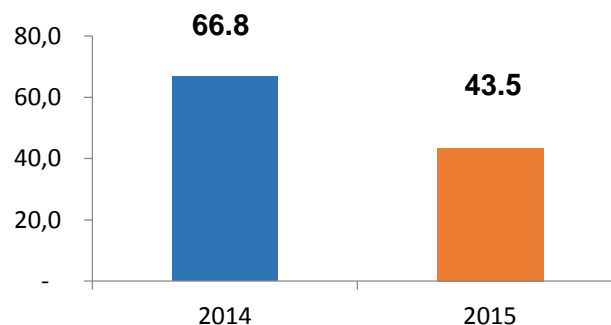

Group results

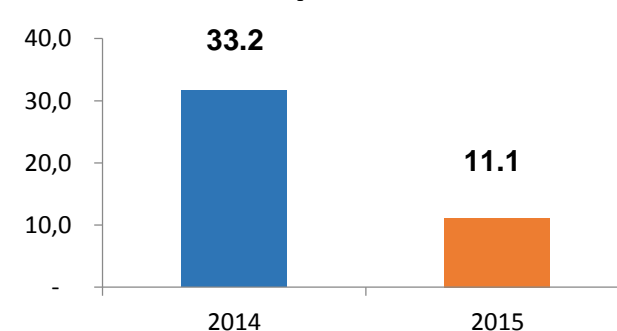

The **2016 value of production**, expected in significant contraction, will be mainly related to Italy orders already in the portfolio. The first quarter showed a value of production of about EUR 100 million which is, together with the related profitability, **in line with** the current year's operating budget.

Business Development

Itinera – Consolidated Financials

(€mln)	2014	2015
Shareholders' Equity	187.3	198.3
Net Financial Position	(21.1)	(29.3)
Debt/Equity	0.11	0.15

Net Financial Position

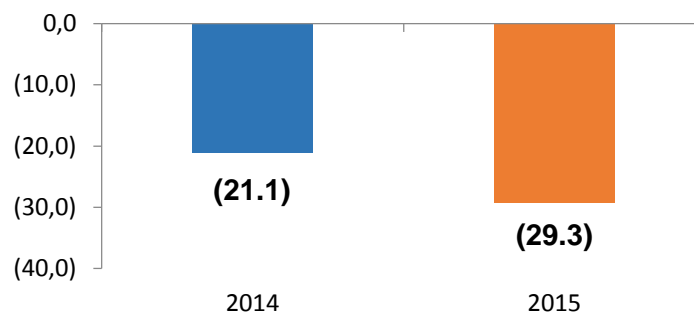

Ratio Debt/Equity

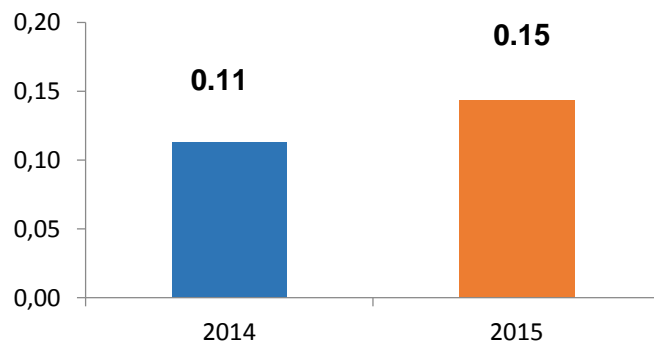

Shareholders' Equity

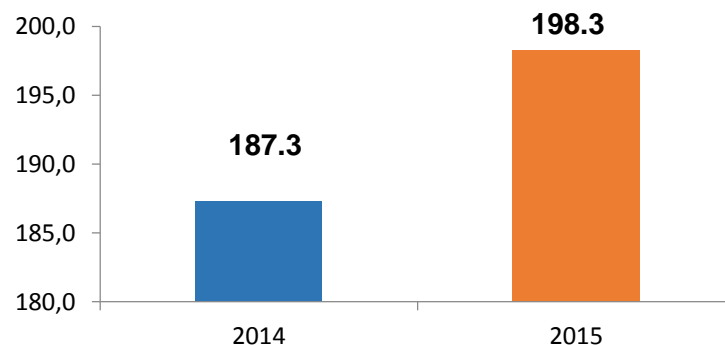

The **Net Consolidated Financial Position** of Itinera as at 31 March 2016 was in line compared to 31 December 2015.

Business Development

Itinera – Backlog as at 31 December 2015

Backlog: EUR 3.8 billion

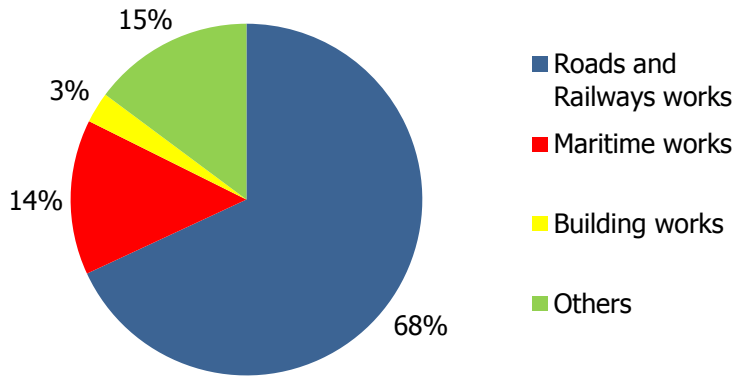

Geographical Breakdown

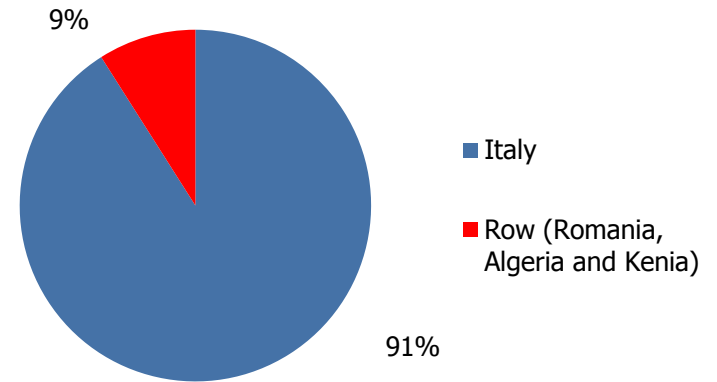

In relation to the **internationalization process** of Itinera during the quarter were completed the procedures for initiation of **new branches in the USA, Kenya, Saudi Arabia** in addition to the already opened units in the second half of 2015.

Foreign Countries Branches already open



ROMANIA
ABU DAHBI
DUBAI
ANGOLA
ZAMBIA
SOUTH AFRICA
ARMENIA
ALGERIA



Foreign Countries Branches - implementation



USA
KENYA
SAUDI ARABIA





Business Development

Itinera – Strategic Targets 2016 - 2020

INTERNATIONAL GROWTH

TARGET REVENUES 2018 onwards: 60% ROW and 40% ITALY

FINANCIALS

Gradual Recovery of the Revenues – TARGET 2020: EUR 1 billion

GRADUAL INCREASE IN MARGINS

MAINTAINING A SOLID FINANCIAL POSITION

NEW INTERNATIONAL TAKE – OVER ORDERS

TARGET 2017/2020: EUR1.5/2.0 billion

OPPORTUNITIES

EVALUATION OF POTENTIAL OPPORTUNITIES FOR GROWTH THROUGH ACQUISITIONS

A vertical list of six items, each preceded by a numbered circle (1-6) connected by a thin line. Each item is followed by a horizontal bar. The first five bars are dark blue, and the sixth bar is light beige.

1	Financial Results
2	SIAS Group Financial Structure
3	Operating Activities
4	Regulatory framework
5	Business development
6	Appendix



Appendix Group Structure

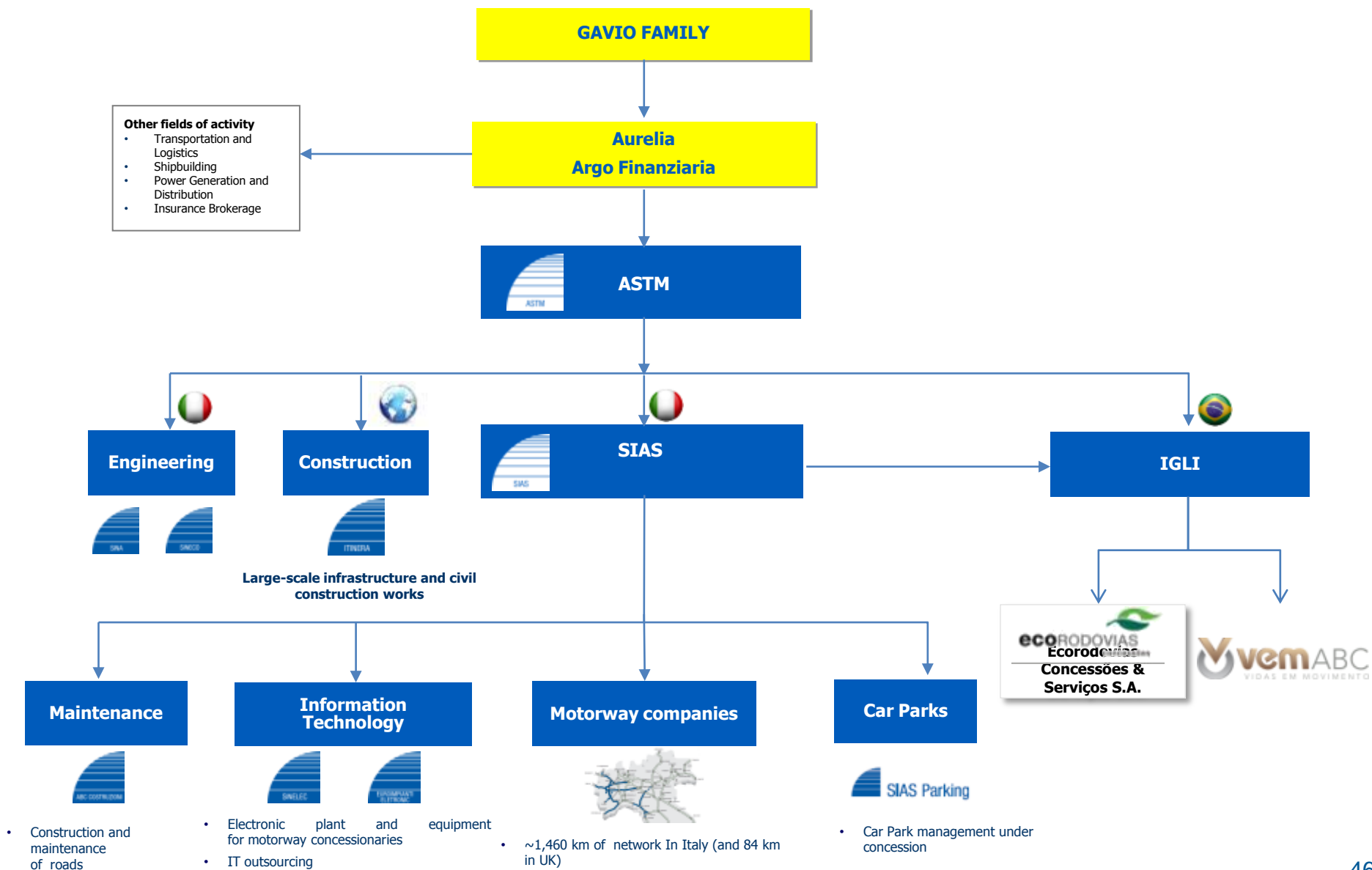



Appendix

Group Structure SIAS and ASTM

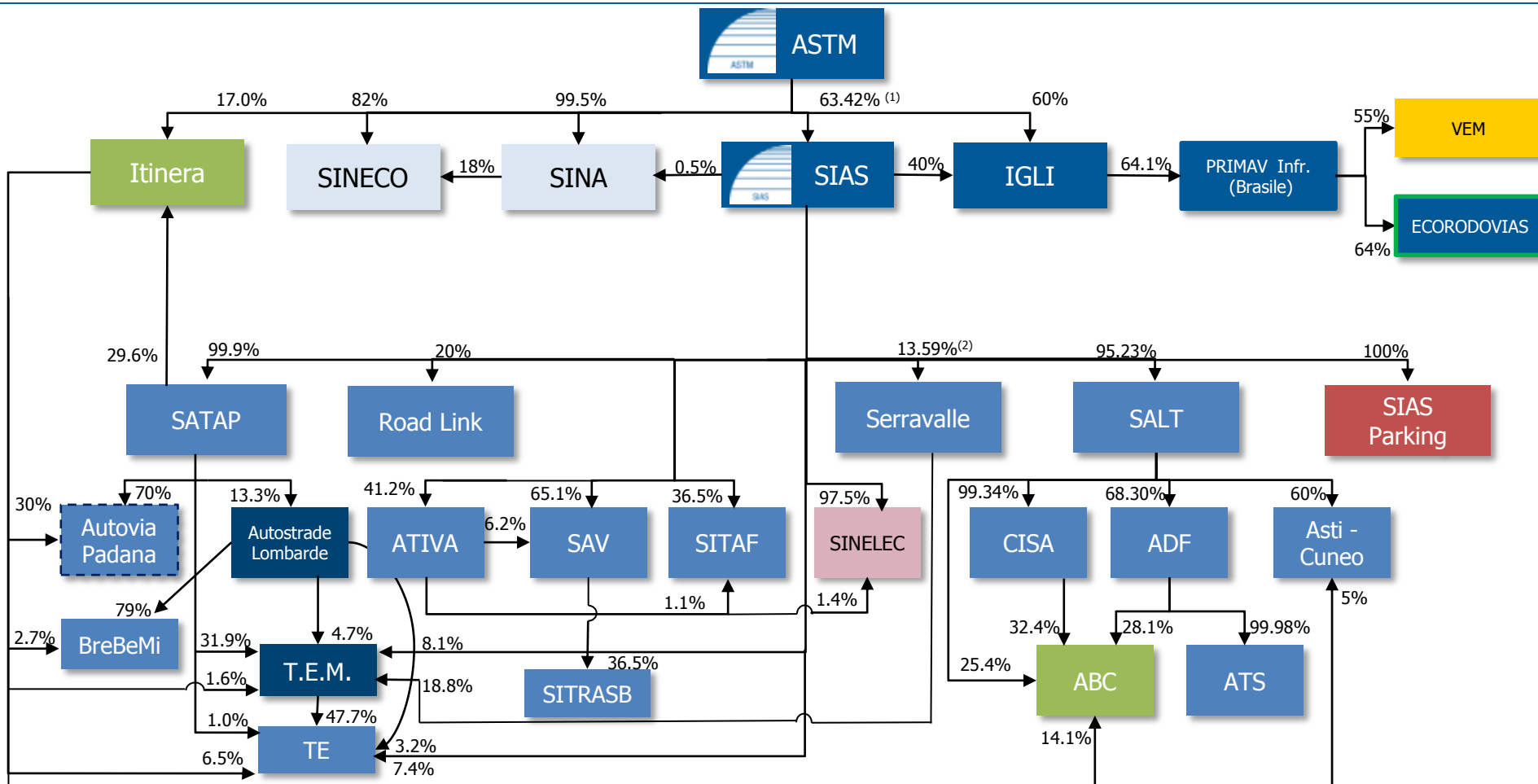

Concessionarie Autostradali

Parcheggi

Holding

Servizi tecnologici (IT)

Società di Costruzioni

Convenzione di concessione in corso di sottoscrizione

Società di Engineering

Concessionarie di mobilità urbana

1) SINA 1.72%
 2) 2,8% owned by ADF



Appendix

SIAS Group financial structure - Available sources of funding as at 31 March 2016

€ million

CASH AND CASH EQUIVALENTS (a)

1,236 ⁽¹⁾

Lender	Total Amount	Borrower	Main Terms
CDP financing	350	SATAP	Maturity Dec. 2025, availability period until 30 June 2018 with low commitment fees
Pool Loans related to Società di Progetto Autovia Padana	270	SIAS	Maturity Dec. 2031, availability period 60 days after the Legislative Decree approving the Concession; availability period line B until December 2020
VAT Pool Loan related to Società di Progetto Autovia Padana	66	AUTOVIA PADANA	Maturity Dec. 2020, availability period: 60 days after the Legislative Decree approving the Concession
Uncommitted bank credit lines	326	SIAS and consolidated companies	
TOTAL UNDRAWN CREDIT LINES (b)	1,012		
TOTAL AVAILABLE SOURCES OF FUNDING (a + b)	2,248		

⁽¹⁾ Cash available	778
Financial Receivables	458
Cash and Cash equivalents	1,236

Appendix

REGULATORY FRAMEWORK: Key Regulatory Protections

Early termination

- Contractual failures that can lead to revocation, withdrawal or termination of the concession agreements are expressly regulated

Indemnity ⁽¹⁾

- In case of early termination of the concession agreements, the concessionaire is entitled to receive an amount (a) determined in accordance with the provision of the relevant concession agreement, (b) reduced by 10% by way of penalty plus damages (only in case of termination due to material breaches of their obligations by the concessionaires)

“Re-alignment of the financial plan”

- The financial plan contained in the concessions agreements needs to be updated every five years (“regulatory period”). In addition, the Regulator or the concessionaires are entitled to request an “extraordinary review” of the financial plan in case of (i) force majeure and/or (ii) additional investments

Penalties and sanctions

- The concessionaires may be required by the Regulator to pay penalties and sanctions in case of material breach or default of certain obligations arising from the concessions agreements

Hand over requirements

- Upon the expiration date of each single concession, the relevant concessionaire is required to transfer the motorways and related infrastructure to the Regulator without any compensation due to it and in a good state of repair. In any event, each concessionaire shall continue to manage the motorway infrastructure up to selection of a new concessionaire

(1) ATIVA and SALT have the right to receive an indemnity as “terminal value” from the new concessionaires for any works executed and not yet amortized as of the expiry date of the relevant concession agreement (terminal value of €101m for ATIVA and €287m for SALT).

Appendix

REGULATORY FRAMEWORK: Toll Formulas

Concessionaire	Tariff formula	
Companies which requested a "re-alignment" of the financial plan ⁽¹⁾		
SATAP (A4 and A21)	$\Delta T = \Delta P \pm X_r + K + \beta \Delta Q$	} 60% of motorways EBITDA
SAV ⁽²⁾	$\Delta T = 70\% * CPI \pm X_r + K$	
CISA ⁽²⁾	$\Delta T = 70\% * CPI \pm X_r + K$	
Companies which requested a "confirmation" of the financial plan ⁽³⁾		
SALT ⁽²⁾	$\Delta T = 70\% * CPI + K$	} 40% of motorways EBITDA
ADF ⁽²⁾	$\Delta T = 70\% * CPI + K$	
ATS ⁽²⁾	$\Delta T = 70\% * CPI + K$	

(1) These companies are allowed to a remuneration both for excess investments made in the previous 5-year regulatory period and for new investments

(2) These companies utilize the "simplified tariffs formula", which includes in the tariff a fixed percentage of the actual inflation (equal to 70%)

(3) These companies are allowed to a remuneration only for new investments

ΔT is the annual tariff increase

ΔP is the annual projected inflation rate as reported in the Italian Budget

X_r is determined every 5 years to remunerate the regulated invested capital at the end of each regulatory period

K is determined every year to remunerate the investments performed during the previous year

X_p is the productivity (or efficiency) factor

CPI is the actual inflation rate for the previous 12 months as reported by ISTAT

βΔQ₁ is the quality factor (related to the status of road surface and the accident rate)



Appendix

EcoRodovias – CAPEX

Reduction in Capex underscores financial discipline and pursuit of efficiency



Actual Pro-Forma CAPEX (R\$ million)

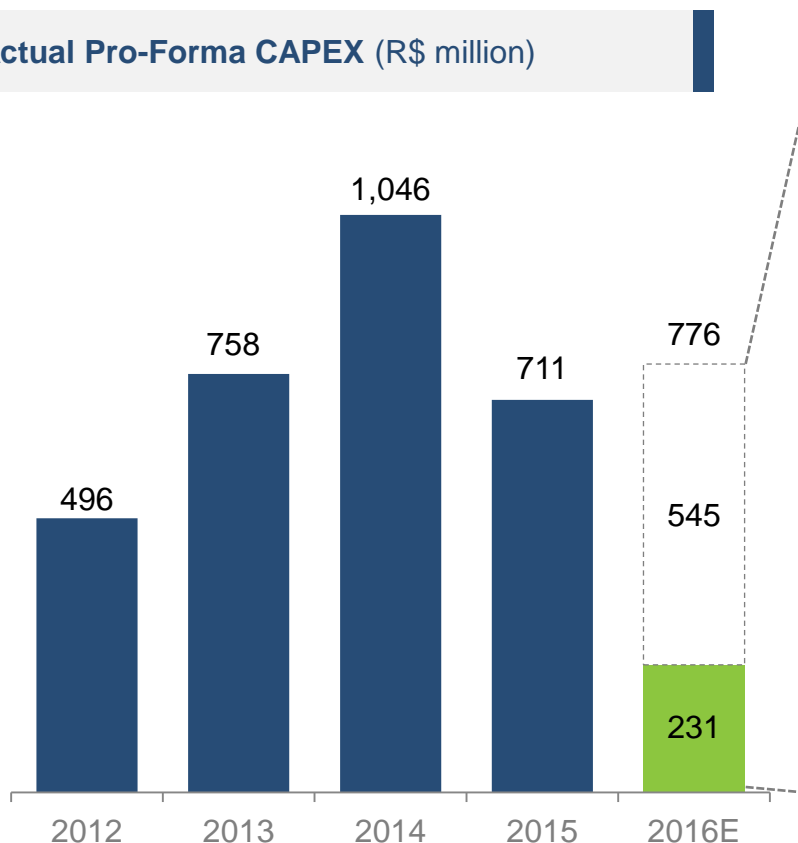

2016 Estimated CAPEX (R\$ million)

Company	Intangible Assets/ PP&E	Maintenance Costs	Total
Ecovias dos Imigrantes	77	64	141
Ecopistas	56	41	97
Ecovia Caminho do Mar	20	6	26
Ecocataratas	50	36	86
Ecosul (100%)	82	5	87
ECO101 (100%)	210	-	210
Ecoponte	113	1	114
Ecoporto Santos	5	-	5
Others ¹	10	-	10
TOTAL²	623	153	776

¹ Includes Services and the Holding Company

² Includes 100% of interest in Ecosul and ECO101

■ CAPEX 2Q16
 □ CAPEX 2H16
 ■ Actual CAPEX

The proportional CAPEX to EcoRodovias' share, estimated for 2016 is approximately R\$680 million



Appendix

EcoRodovias – Debt

Gross Debt by type (R\$ million and % Jun/2016)

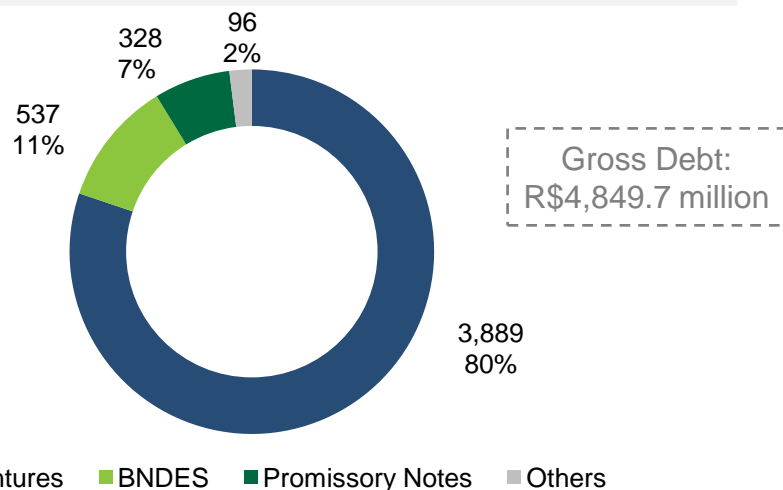

Gross Debt by index (R\$ million and % Jun/2016)

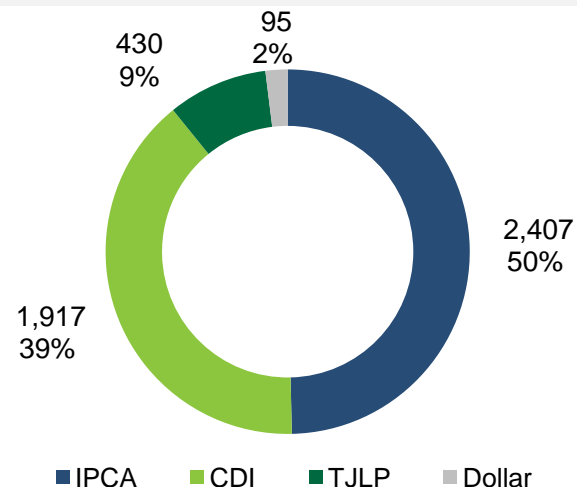

Net Debt¹ (R\$ million)

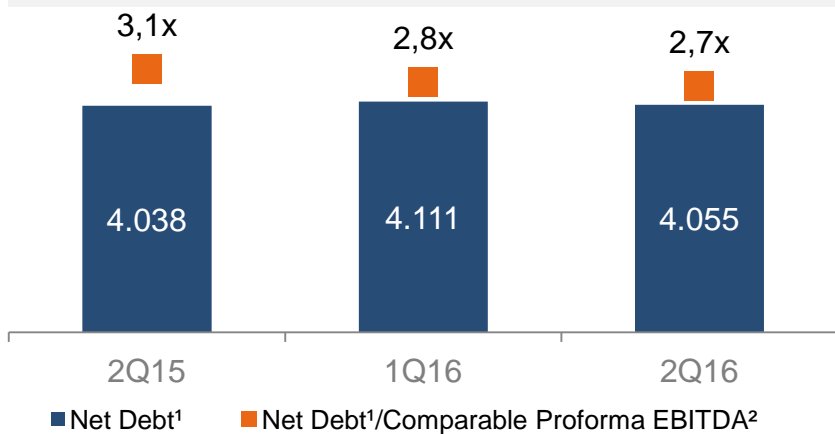

**Flexibility in capital allocation
prioritize deleveraging**

¹ Assets held for sale (Elog) aren't consolidated;

² Excludes Provision for Maintenance, Elog results and Impairment at Ecoporto (non-recurring and non-cash).



Business Development

EcoRodovias – Debt

Lengthened debt profile strengthens financial health

Debt Amortization Schedule¹: R\$4,849.7 million - (R\$ million)

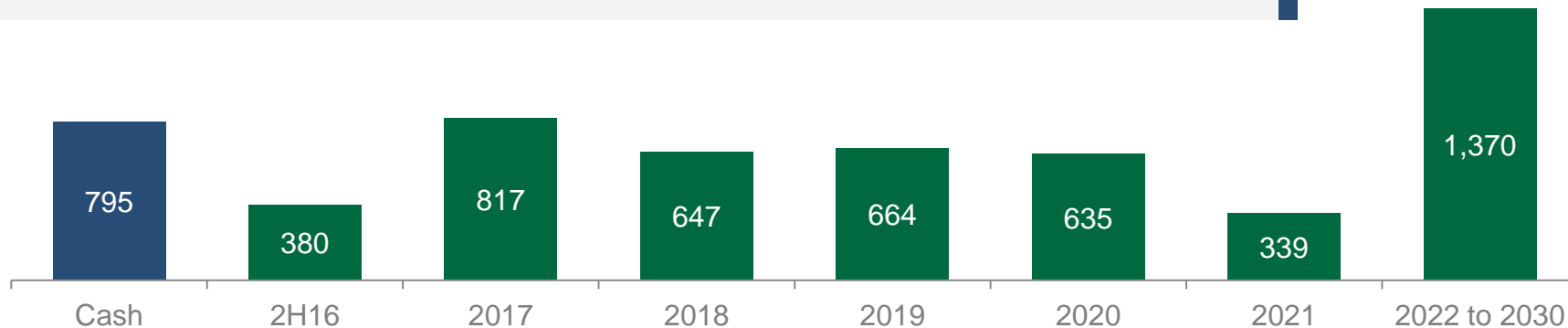

Debt breakdown of 2016 - (06/31/2016)

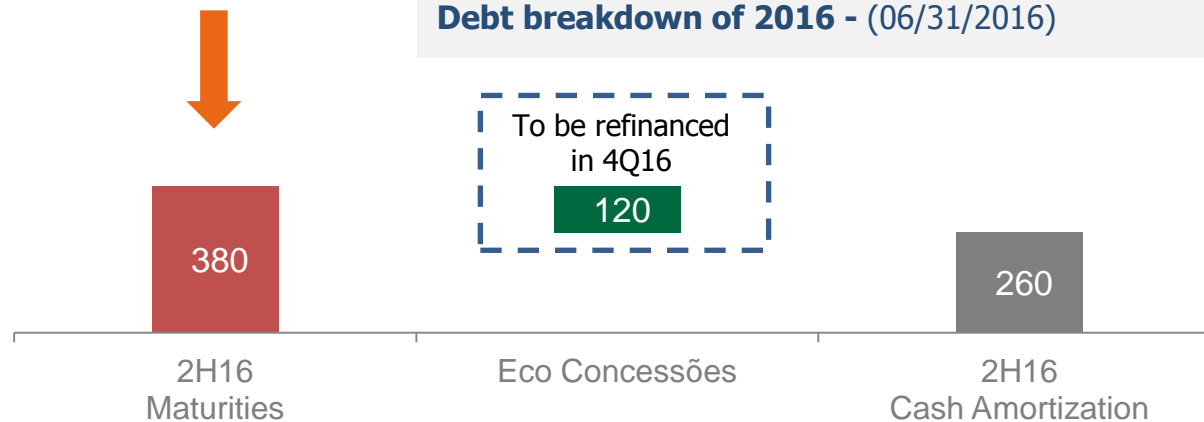

¹ Don't consolidate costs and expenses from assets held for sale (Elog).



Business Development

EcoRodovias – Opportunities for Growth

Nº	Highway	Total extension (km):	Estimated investments (R\$ billion)
1	BR-163/MT/PA	976	6.6
2	BR-364/060/MT/GO	704	4.1
3	BR-364/GO/MG	439	3.1
4	BR-476/153/282/480/PR/SC	460	4.5
5	BR-101/232/PE	564	4.2
6	BR-346/RO/MT	806	6.3
7	BR-101/BA	199	1.6
8	BR-262/281/MG	305	1.9
9	BR-262/MS	327	2.5
10	BR-267/MS	249	2.0
11	BR-101/493/465/RJ/SP	357	3.1
12	BR-280/SC	307	2.1
13	BR-470/282/SC	455	3.2
14	BR-101/SC	220	1.1
15	BR-101/116/290/386/RS	581	3.2
Total		3,870	49.5

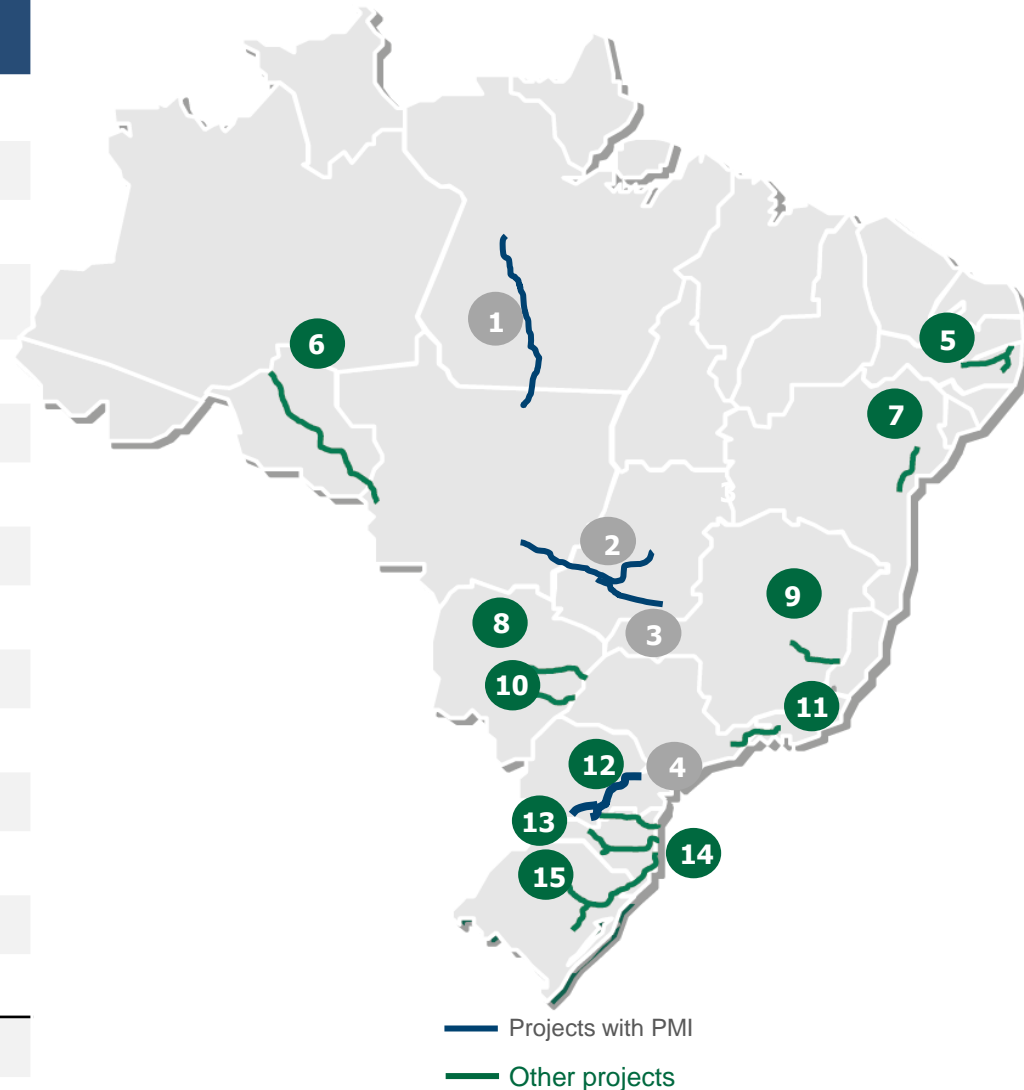

¹Source: Ministry of Planning

Business Development

EcoRodovias – Opportunities for Growth – State of Sao Paulo

Concession of 2,266 km of state highways, divided into 4 lots of highways crossing the state of São Paulo transversally in the Paraná - Minas Gerais direction

Lot	Total extension (km):	Estimated investments (R\$ billion)
Lot A	116	1.2
Lot B	481	2.3
Lot C	1,097	4.6
Lot D	572	2.7
Total	2,266	10.8

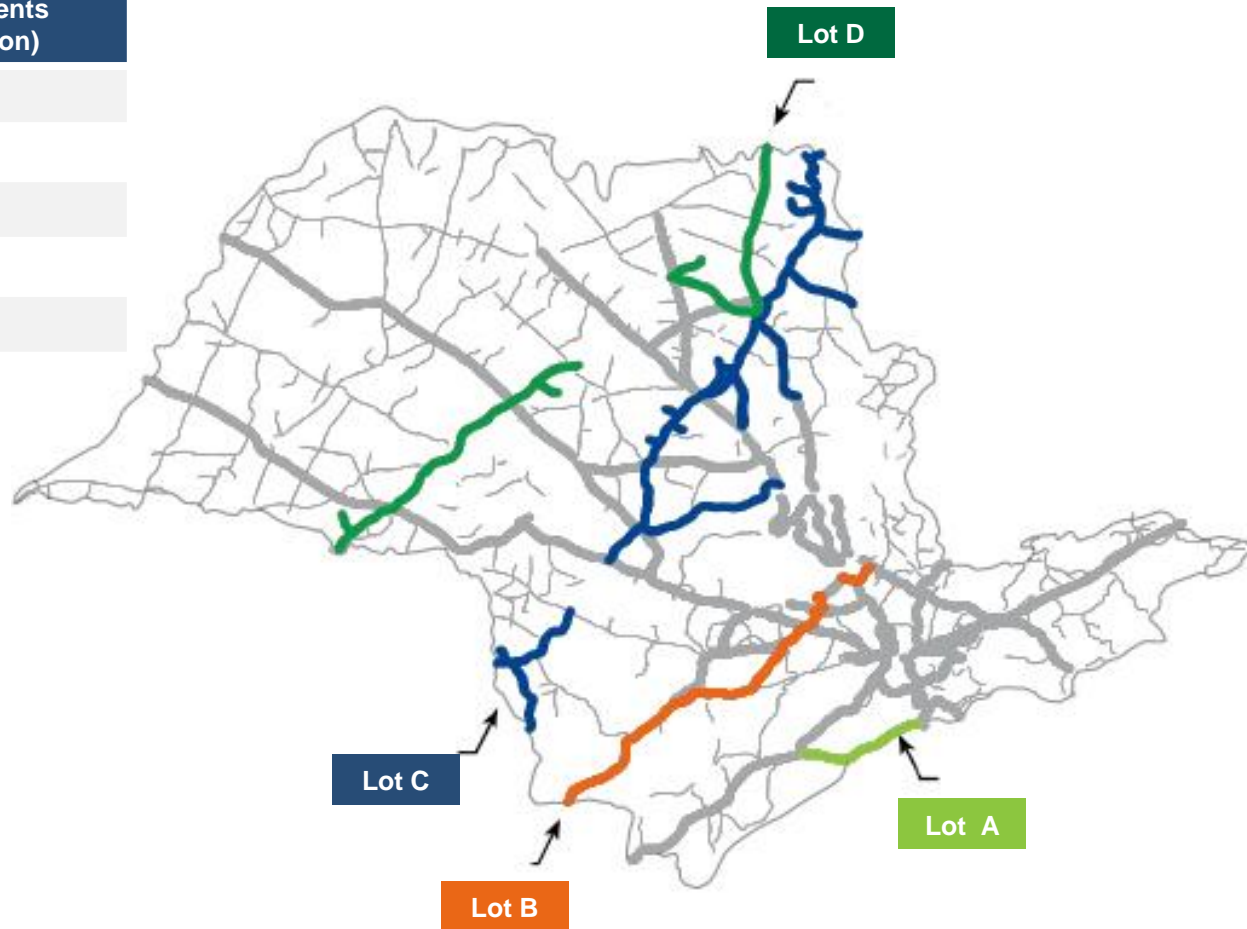



www.astm.it

www.grupposias.it