



# COMPANY PRESENTATION

Virtual STAR Conference,  
Fall edition 2021



# DISCLAIMER

*Certain statements in this slide show, including those addressing the Company's beliefs, plans, objectives, estimates or expectations of possible future results or events, are forward-looking statements. Forward-looking statements involve known or unknown risks, including general economic and business conditions, and conditions in the industry we operate and may be affected should our assumptions turn out to be inaccurate. Consequently, no forward-looking statement can be guaranteed and actual future results, performance, or achievements may vary materially from those expressed or implied by such forward-looking statements. The Company undertakes no obligation about the contents nor to update the forward-looking statements to reflect events or circumstances that may arise after the date hereof.*



# AGENDA

1. Overview
2. Markets and Growth drivers
3. Innovation: products & applications
4. Financial Highlights
5. Current Outlook
6. Multiples & Comparables



# Overview



# Overview



## A primary player providing Medical, Industrial and Conservation Laser Solutions Worldwide



### World Class Hi-Tech company

Hi-Tech industrial group providing laser solutions with proprietary technologies and know how developed over 40 years



Listed on Milan's Stock Exchange Star segment since year 2000



### Within Worldwide leaders in its space

Active worldwide on several laser application segments and markets...



...progressively widening its worldwide presence achieving continuous growth over the years



# Our businesses



40

years of experience



20

subsidiaries



7

Countries with direct presence



13

Plants

## WE CREATE LIGHT, ENERGY, WAVES

### Medical

Our energy based systems improve people's well-being and life quality.

In the **surgical sector**, our minimally invasive technology systems minimize pain, side effects and risks of surgical procedures and hospitalization days.

In the **aesthetic sector**, our systems satisfy the growing desire of individuals to improve their appearance also reducing pathological or painful imperfections



### Conservation

Our **laser systems preserve** artworks of the universal heritage of our communities.



### Industrial

Our **laser cutting** and **marking systems** reduce the environmental impact of manufacturing processes minimizing waste, fumes generated by the process, use of chemical additives, also allowing to eliminate the need for inks, solvents or glues within the process.







**MSCI**  
ESG RATINGS

# Our approach



## OUR STRATEGY FOR A SUSTAINABLE FUTURE:

Create value over time and be ready to successfully meet the future challenges

### R&D



**8**  
R&D dept.



**>16 mln**  
yearly R&D investments



**> 130**  
patents



**> 150**  
R&D specialists

### PRODUCTS



**> 50.000**  
Laser sources produced



**ISO 9001 e ISO 13485**  
Certifications



**> 60**  
Quality specialists

### PEOPLE

**~25%**  
under 30  
years

**~ +10%**  
2020  
headcount



**>1.600**  
employees



**Welfare** at the heart of business projects.  
Workspaces were renewed for several Group companies: employees well-being increase and improvement of plants' energy efficiency



**>27,000 hours**  
training

### ENVIRONMENT



**2**  
Photovoltaic plants set up  
in 2020



**+7%**  
Self-generated and consumed  
electrical supply

# Our History



**80s**

Production of CO<sub>2</sub> lasers for dermatology, surgery and therapy

**1981**

Incorporation of **El.En. S.n.c**

**1990 - 1993**

Incorporation of:  
**Deka MELA S.r.l.**,  
**Lasit S.r.l.**,  
**Cutlite Penta S.r.l.**



**2000**

**El.En. S.p.A.** listed on the Italian stock market

**2002**

Acquisition of **Cynosure Inc.**

**2003**

Acquisition of **Asclepion GmbH**

**2004**

Acquisition of **Quanta System**

**2005**

Acquisition of **ASA S.r.l.**

**Cynosure Inc.** listed on the Nasdaq

**2007**

Incorporation of chinese JV  
**Wuhan Penta Chutian Co. Ltd**

Incorporation of **Cutlite Do Brasil Alta Tecnologia Ltda**

Acquisition of **With Us**

**2009**

Incorporation of **Esthelogue S.r.l.**

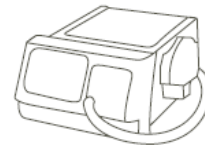

**2013**

Incorporation of second chinese JV  
**Penta Laser Equipment (Wenzhou) Co. Ltd**

**2019**

Incorporation of **Penta Laser Technology (Shangdong) Co. Ltd**



**2021**

Incorporation of **Lasit Laser Polska**

**2016**

**Deka M.E.L.A.** and **Quanta System** merge their commercial brand names into **Renaissance®** for the Italian market

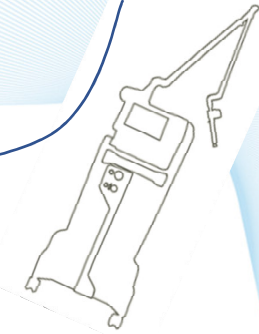



# El.En. Worldwide

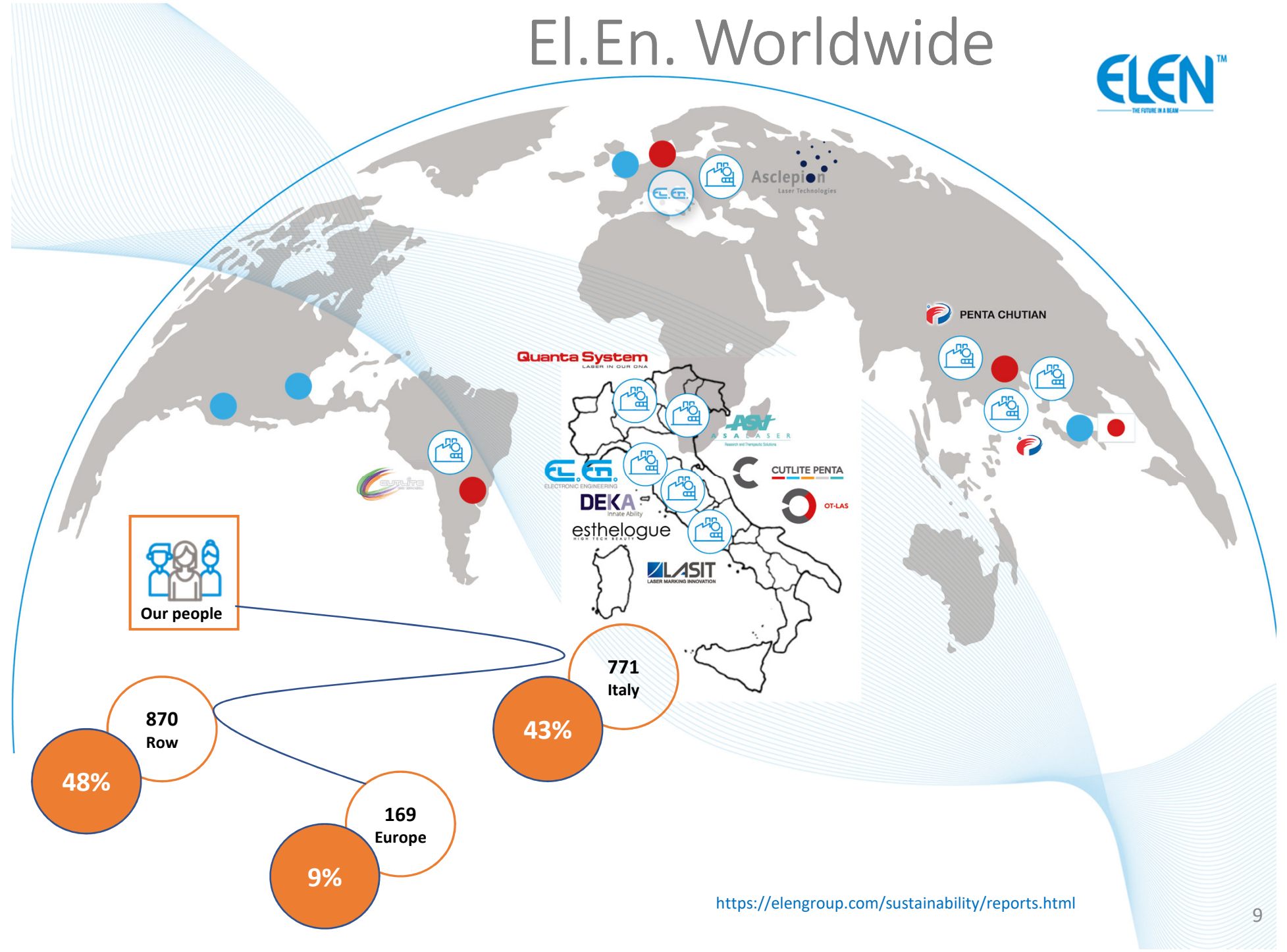

# Growth history



## Revenues

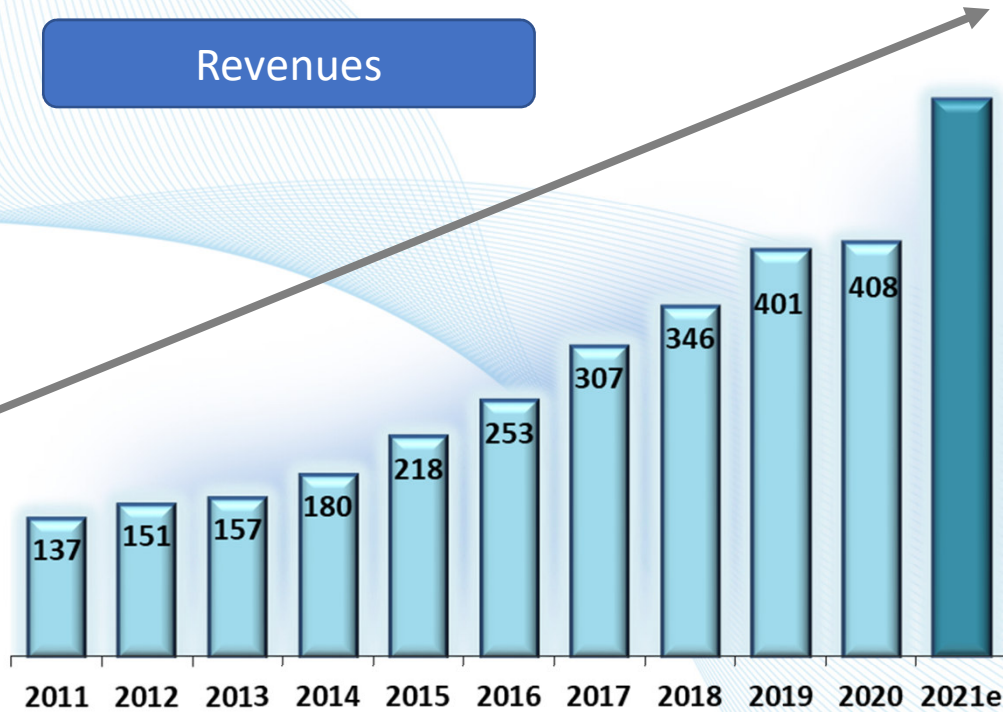

Cagr 11/20:  
+13%

## EBIT

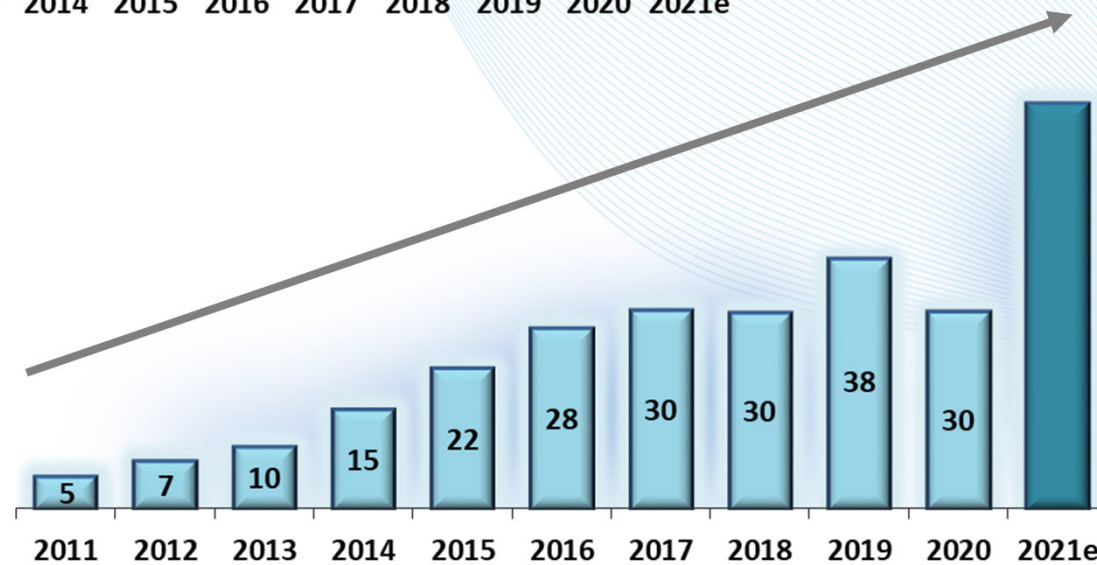

Cagr 11/20:  
+22%

*in Euro million*





Markets and Growth drivers

# Long term market trends

**ELEN™**  
THE FUTURE IN A BEAM

## Aesthetics:

- Aging population
- Growing global obesity rate
- Increasing desire of individuals to improve their appearance
- Lower procedure cost, attracting a broader consumer base

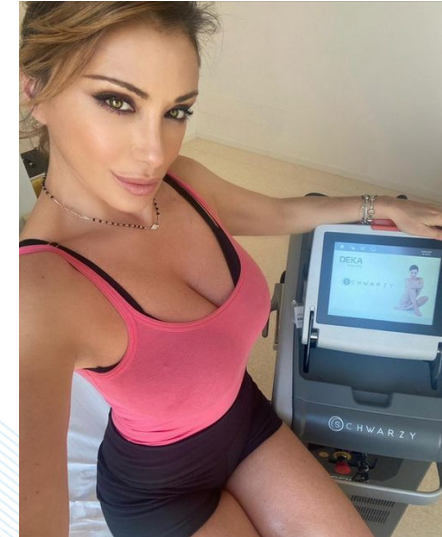

## Minimally invasive surgeries:

- Painless procedures
- Side effects and risks reduction
- Hospitalization days reduction
- Savings by Private & National Health Systems
- Attractive ROI for surgical services providers





# Long term market trends



## Laser cutting applications:

- Laser power increase + Cost reduction:  
Enhanced flexibility, productivity and quality standards in manufacturing processes
- New application verticals
- Building and construction

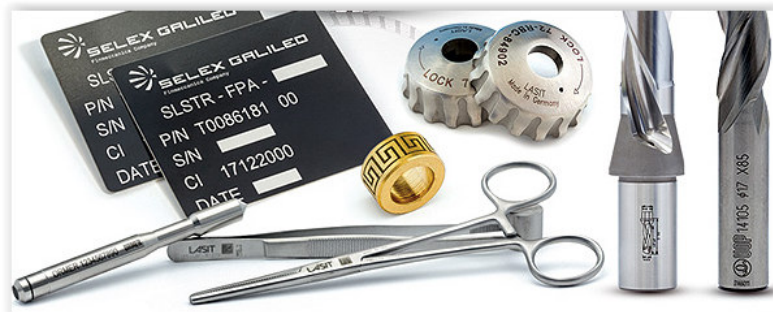

## Laser marking:

- Products identification and traceability
- Minimal environmental impact

# Medical Aesthetics: Market Overview (pre-Covid)

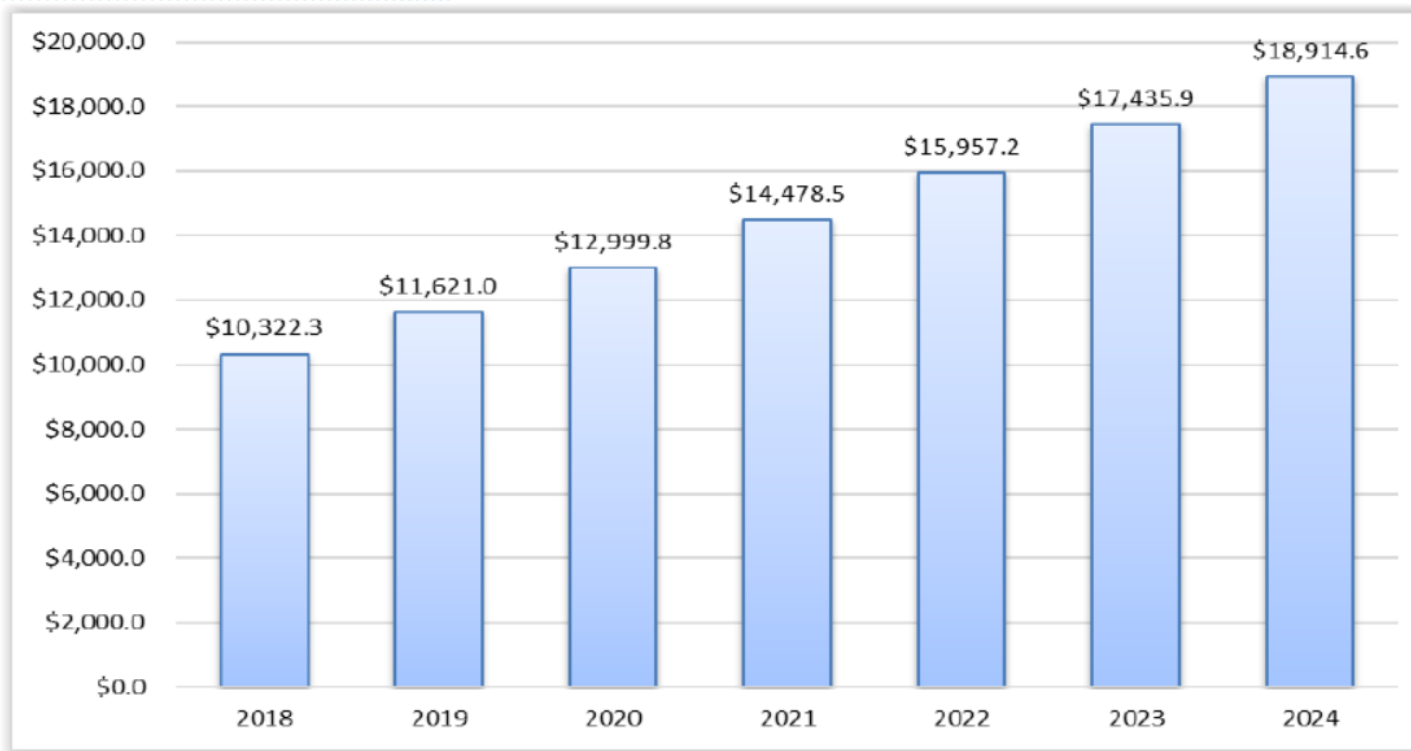

**Daniel Associates:**  
Medical aesthetics  
market 2018 to 2023  
**10.23% CAGR**

Source: Daniel Associates

## Key growth drivers:

- Aging population
- Desire to achieve and maintain youthful appearance
- Increase in healthcare spending
- Requirements for fast and minimally invasive surgical procedures



# Medical Aesthetics: Market Overview

	<b>2018</b>	<b>2024</b>	<b>Cagr</b>
Facial Aesthetics Products	1.831	3.638	10,7%
Body Contouring Devices	1.708	3.172	10,3%
Cosmetic Implants	1.321	2.415	10,0%
Physician-dispenced cosmoceuticals and skin	1.104	1.903	10,2%
Skin Aesthetic Devices	938	1.762	10,2%
Physician-dispenced eyelash products	910	1.551	10,0%
Hair removal devices	783	1.432	10,0%
Tattoo removal devices	87	153	9,9%
Thread lift products	73	125	9,8%
Nail treatment laser devices	61	110	9,5%
	<b>8.816</b>	<b>16.261</b>	

Source: Daniel Associates



	<b>2018</b>	<b>2024</b>	<b>Cagr</b>
North America	3.147	5.689	9,9%
Europe	1.958	3.480	9,4%
Asia Pacific	2.343	4.635	11,6%
Middle East&Africa	822	1.492	9,8%
Latin America	547	965	9,4%
	<b>8.816</b>	<b>16.261</b>	

# Medical Laser Market



Medical Laser Market - Growth Rate by Region

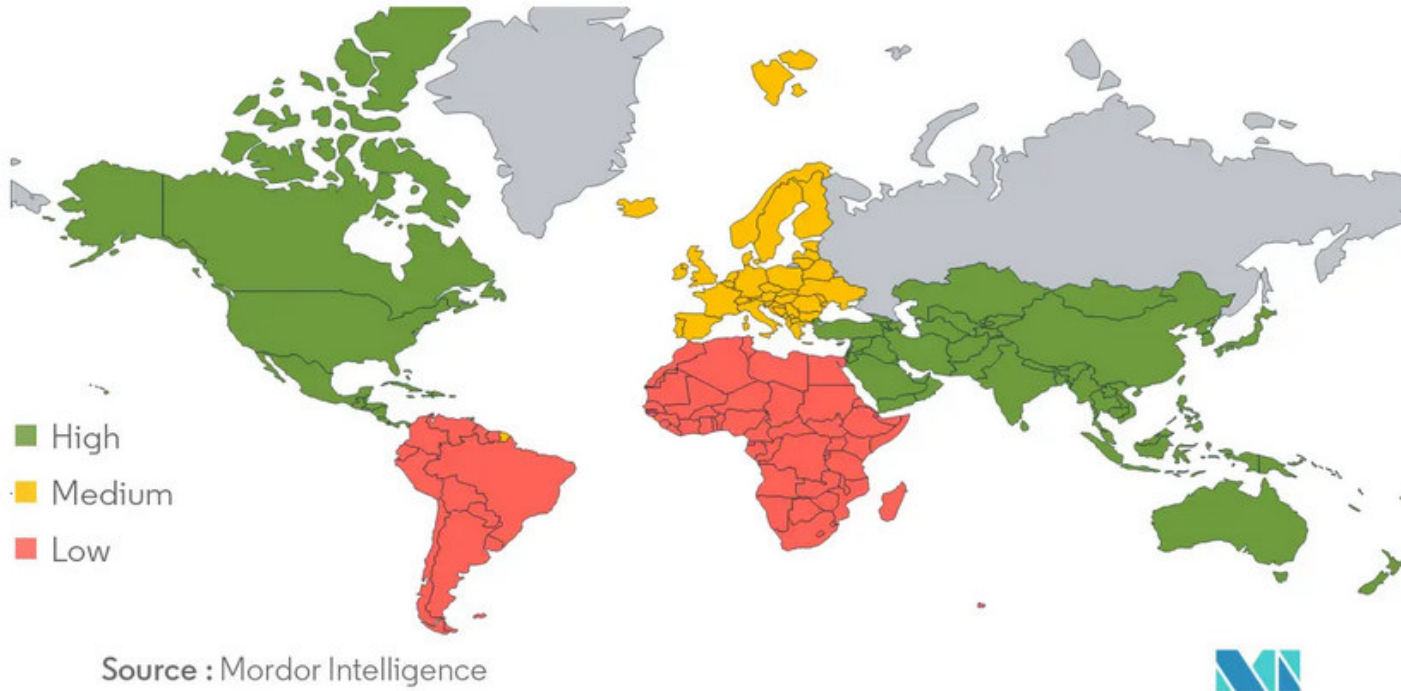

### Fortune Business Insights:

The global Medical Laser Market size was valued @ USD 4,37 billion in 2019 and is projected to reach USD 10,57 billion by 2027, exhibiting a CAGR of **13,9%** during the forecast period

### Market & Research:

The global energy based aesthetic devices market is estimated at \$ 4.0 B today and is projected to grow \$ 8.4B by 2021 with a **12% CAGR**





# Industrial laser market



Laser systems increasingly adopted in high quality manufacturing for uniqueness, flexibility, environment friendliness, productivity

- Sheet metal cutting: technology breakthroughs leading to strong demand expansion
- Laser marking for identification: traceability as a quality standard

## MARKET STUDIES:

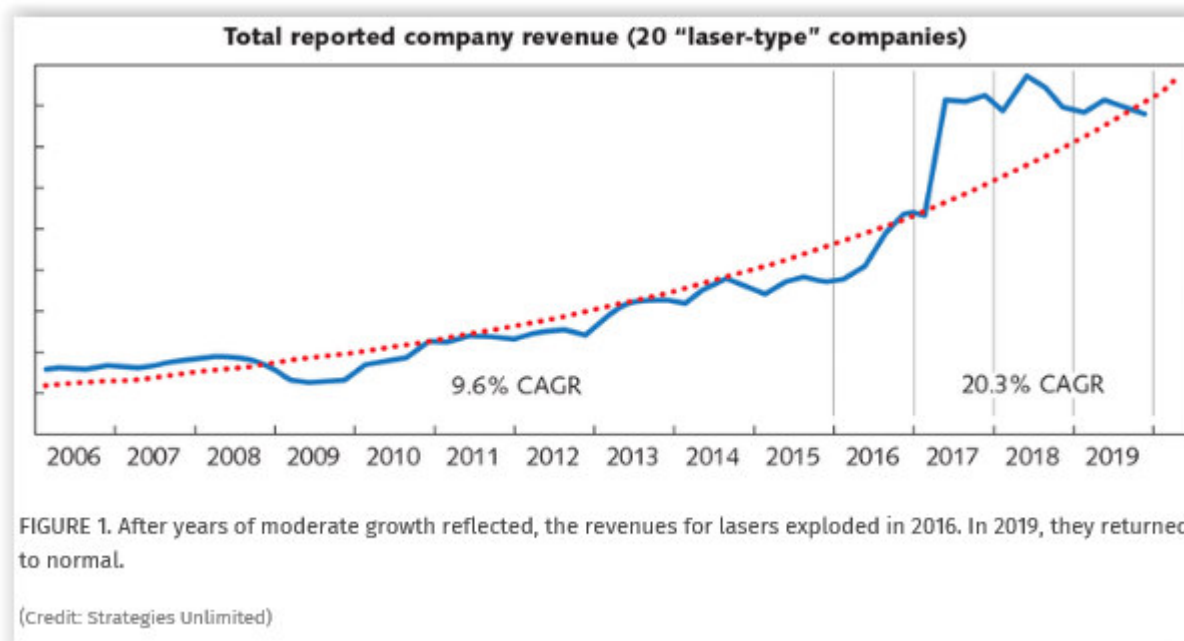

**ResearchAndMarkets's analysts forecast :**  
"The global industrial lasers systems market size was valued at \$20,120.2 million in 2018, and is projected to reach \$36,510.6 million by 2026, growing at a CAGR of 7.5% from 2019 to 2026"

# Growth drivers

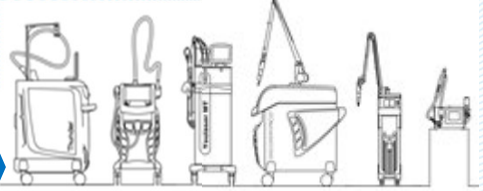
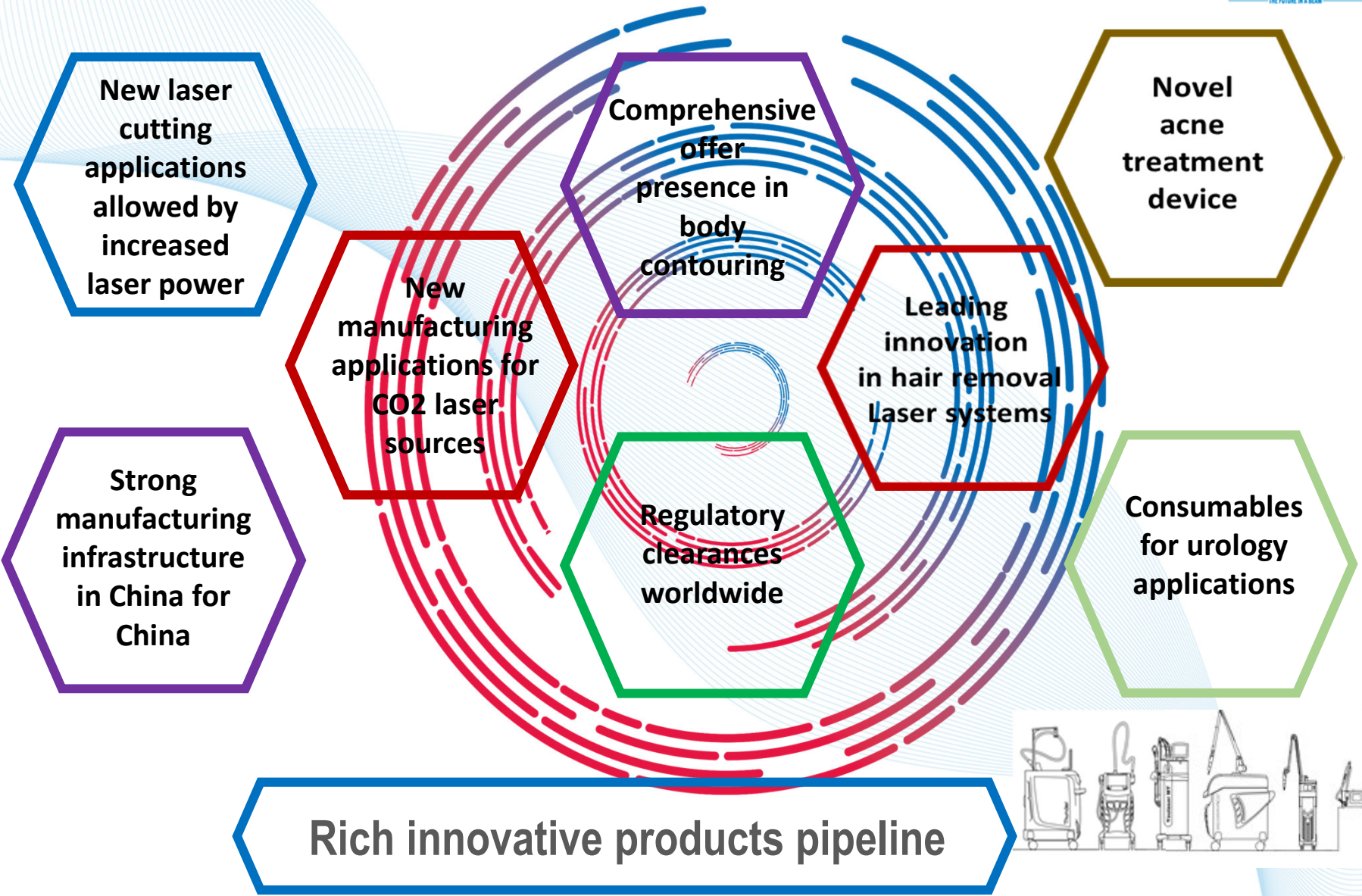



**DEKA**  
Innate Ability

**Asclepiion**  
Laser Technologies

**ASV**  
A S A L A S E R  
Research and Therapeutic Solutions

**esthelogue**  
HIGH TECH BEAUTY

**Quanta System**  
LASER IN OUR DNA

 **PENTA CHUTIAN**

**LASIT**  
LASER MARKING INNOVATION

 **CUTLITE**  
LASER TECHNOLOGY

 **CUTLITE PENTA**

 **OT-LAS**

Innovation: products & applications

# Expanded product portfolio for body contouring, cellulite treatments

## ONDA Plus (Coolwaves)

Improved capabilities of our body contouring flagship system



## Physiq, Delinea, B-Star

An effective set of unique combinations of superluminescent led matrices with Tens and EMS



## Schwarzy, B-Strong, Bodylab

High intensity magnetic fields for muscles stimulation



## New Icoone Laser

Micro alveolar stimulation





# Expanded product portfolio for epilation, skin firming



## Again

Unique high end system for laser hair removal

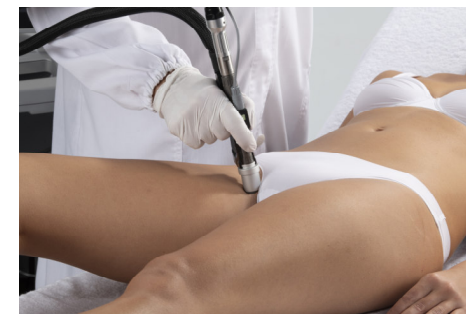

## Luxea

The ultimate multi application and multi technology platform



## RED Touch

The system for neocollagenesis and tissue regeneration



# Tattoo and Toning



**Discovery Pico Derm**  
Designed for Asian skins

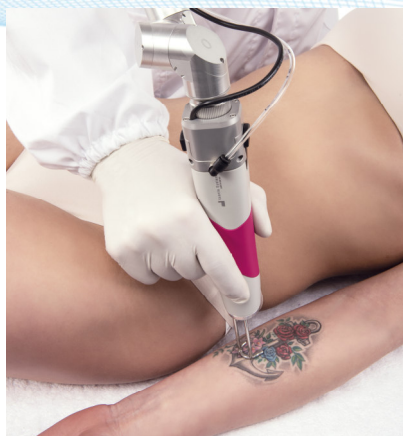

**Chrome Station**  
Three wavelengths multi  
platform

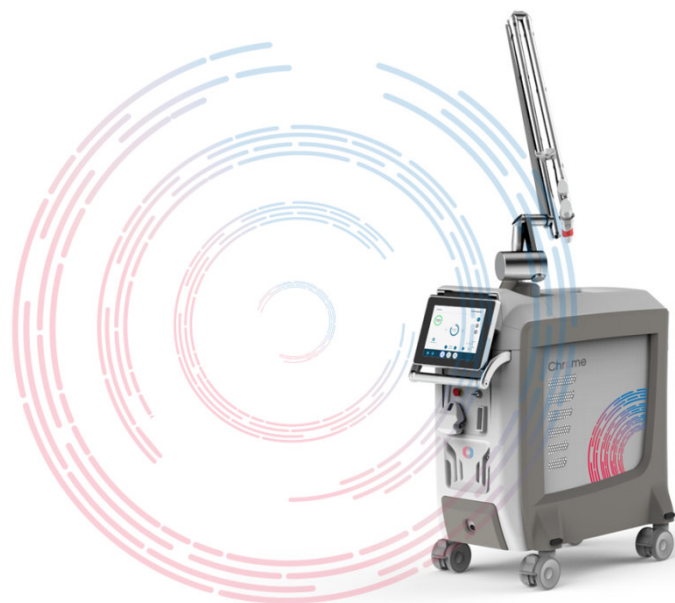



# Tattoo and Toning



## Chrome LASE-STATION

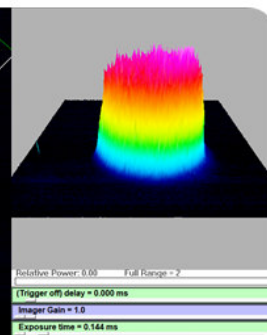
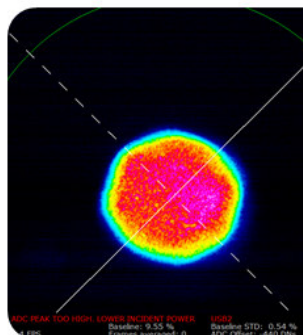
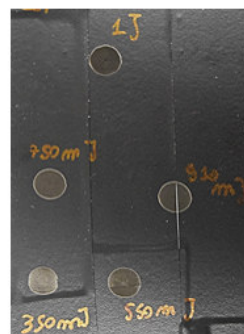
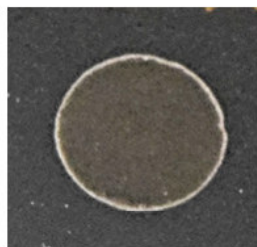

## Competition

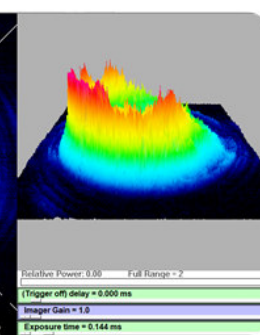
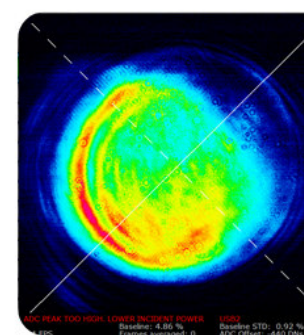
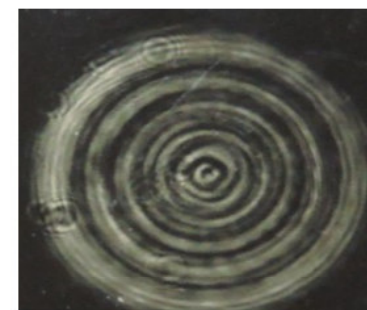

# Acne



## The Accure Advantage



Courtesy: Emil [Tanghetti](#), MD

June 29, 2019

January 14, 2020



# Urology



A complete line of Holmium lasers from 25 W to 155 W

## New FIBER DUST

One of two worldwide players in high power medical fiber lasers



fiber  
D U S T



## New UHPTDL

Our novel disruptive technology for the most effective stones micro fragmentation

# MonnaLisa Glide



**Novel CO<sub>2</sub> device** for dermatology and gynecology  
featuring an additional 1540nm laser source





# Physiotherapy



MiS (MLS Family)  
For degenerative neuropathies



# Industrial lasers systems



## STEEL CUTTING

10 kW Average power in 2020 sales bookings

40 kW systems to come in 2021

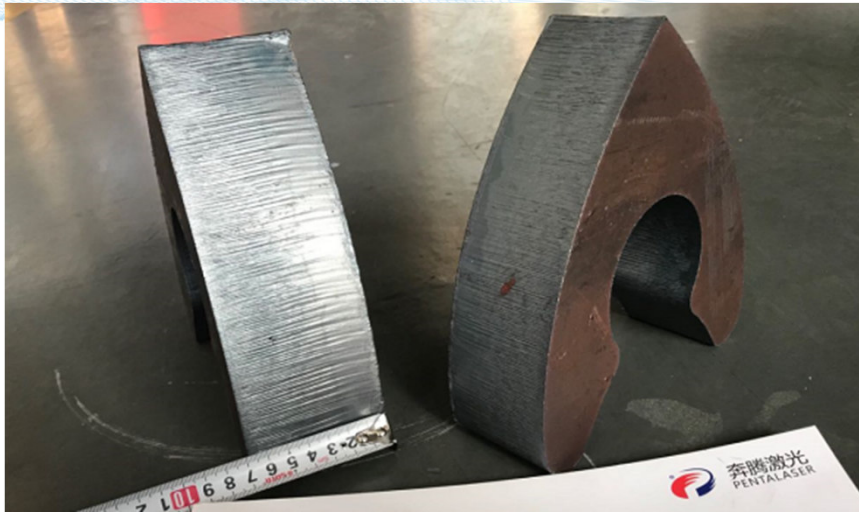



# Laser cutting systems offer in China



## 一、高功率激光切割机床的技术创新 Technical innovation of high power laser cutting machine tools



### 飞越6 (SwingVI) 的技术创新 Tech. innovation on Swing VI

特点: feature

#### 设计定位 Design orientation:

1. 最经济可靠的高功率激光机床;  
1.The most economical and reliable high-power laser machine tools
2. 意大利CNC, 德国普雷切割头;  
2. Italy CNC, Germany cutting head;
3. 独一无二的高功率切割工艺;  
3. Unique high power cutting technology;
4. 大众定价: 130-320万元 (12-30kW)  
4.Pricing: 1.3 million to 3.2 million yuan (12-30kW)。

经济实用,  
Economical and practical,

牛年热销!  
hot sale

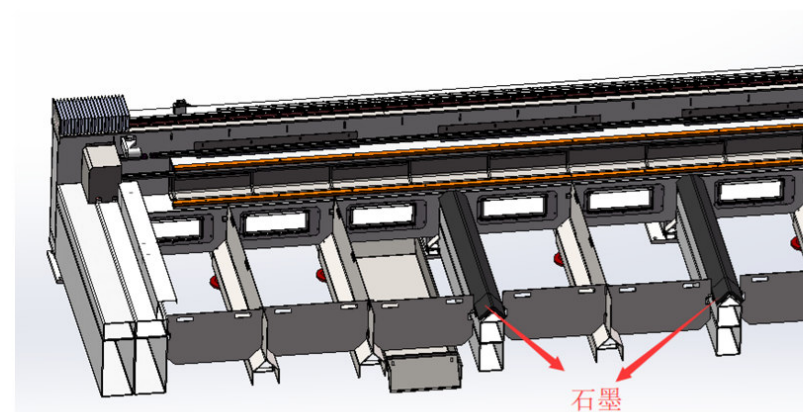
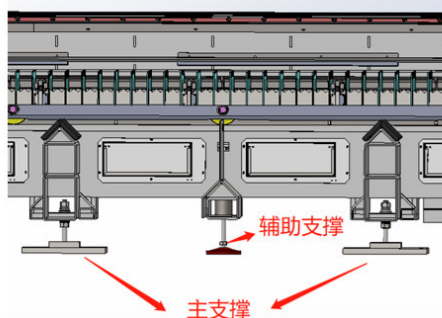



# Financial Highlights



# Income Statement – H1 2021



Euro '000	30/06/19	%	30/06/20	%	30/06/21	%	Cagr %
Medical	112.129	59,5%	100.309	61,7%	146.688	53,6%	14,4%
Industrial	76.321	40,5%	62.212	38,3%	127.223	46,4%	29,1%
<b>Revenues</b>	<b>188.450</b>	<b>100,0%</b>	<b>162.521</b>	<b>100,0%</b>	<b>273.911</b>	<b>100,0%</b>	<b>20,6%</b>
<b>Gross margin</b>	<b>74.385</b>	<b>39,5%</b>	<b>59.877</b>	<b>36,8%</b>	<b>99.915</b>	<b>36,5%</b>	<b>15,9%</b>
Operating Expenses	21.515	11,4%	16.058	9,9%	20.763	7,6%	-1,8%
Staff expenses	32.266	17,1%	29.334	18,0%	40.015	14,6%	11,4%
<b>EBITDA</b>	<b>20.604</b>	<b>10,9%</b>	<b>14.485</b>	<b>8,9%</b>	<b>39.138</b>	<b>14,3%</b>	<b>37,8%</b>
Depr., amort., accruals	3.891	2,1%	5.197	3,2%	8.280	3,0%	45,9%
<b>EBIT</b>	<b>16.713</b>	<b>8,9%</b>	<b>9.288</b>	<b>5,7%</b>	<b>30.857</b>	<b>11,3%</b>	<b>35,9%</b>
Net financ.income(charges)	267	0,1%	(219)	-0,1%	1.088	0,4%	101,9%
Other income (expense) net	(86)	0,0%	(126)	-0,1%	(111)	0,0%	13,8%
<b>EBT</b>	<b>16.894</b>	<b>9,0%</b>	<b>8.943</b>	<b>5,5%</b>	<b>31.835</b>	<b>11,6%</b>	<b>37,3%</b>
Income taxes	4.675	2,5%	2.139	1,3%	6.928	2,5%	21,7%
Minorities	1.996	1,1%	403	0,2%	2.457	0,9%	10,9%
<b>NET INCOME</b>	<b>10.223</b>	<b>5,4%</b>	<b>6.401</b>	<b>3,9%</b>	<b>22.451</b>	<b>8,2%</b>	<b>48,2%</b>

# Balance Sheet – H1 2021



Euro '000	31/12/20	30/06/21	Var.%
Total non current assets	116.838	125.659	7,5%
Net Working Capital	110.679	135.099	22,1%
Other receivables/payables ST	(37.946)	(63.409)	67,1%
Net financial position	64.168	78.857	22,9%
Long term liabilities	13.074	15.191	16,2%
Net Equity	240.665	261.014	8,5%
Net capital employed	176.497	182.157	3,2%
Net Working Capital on sales	27,1%	24,7%	
ROCE (EBIT/Net capital employed)	17,1%	33,9%	
Capex	12.941 <small>12 months</small>	11.149 <small>6 months</small>	



# Cash Flow

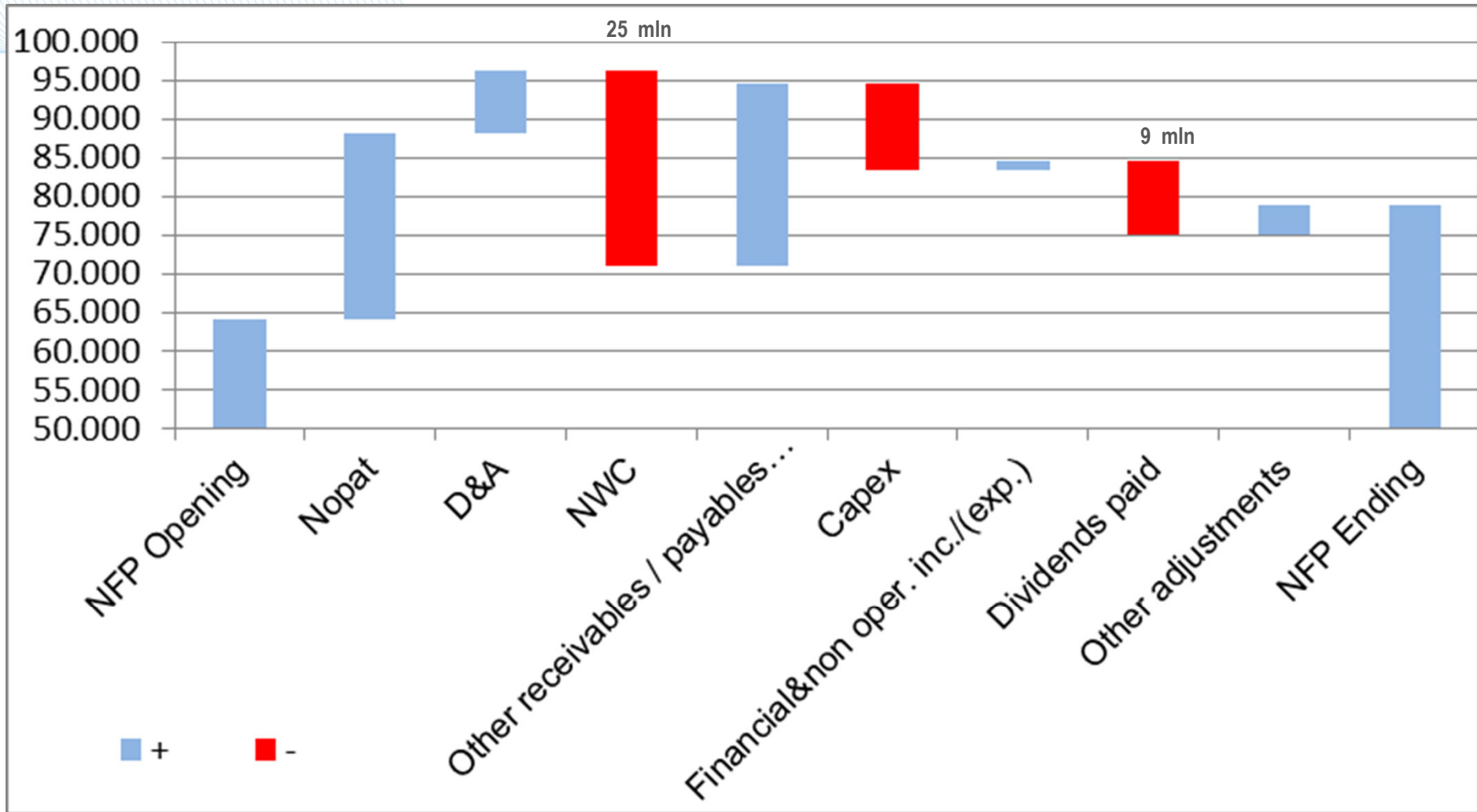

# Revenue breakdown by business

**Medical**  
Cagr 19/21:  
+14%

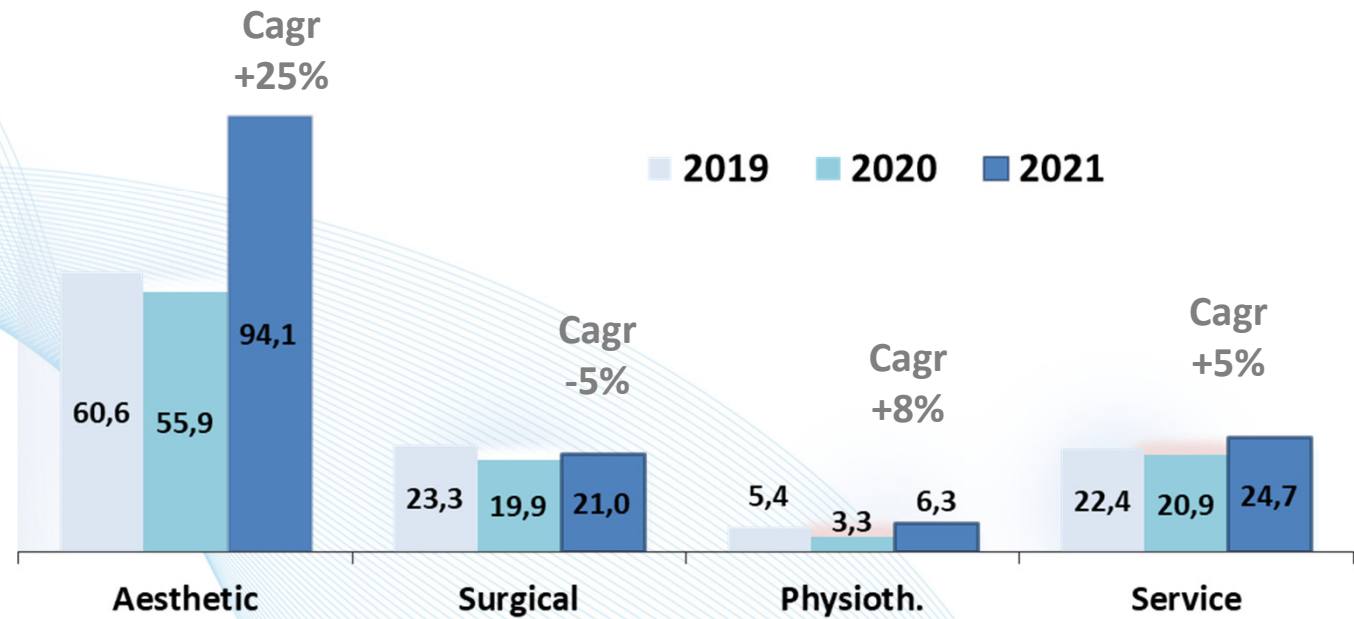

**Cagr**  
+35%

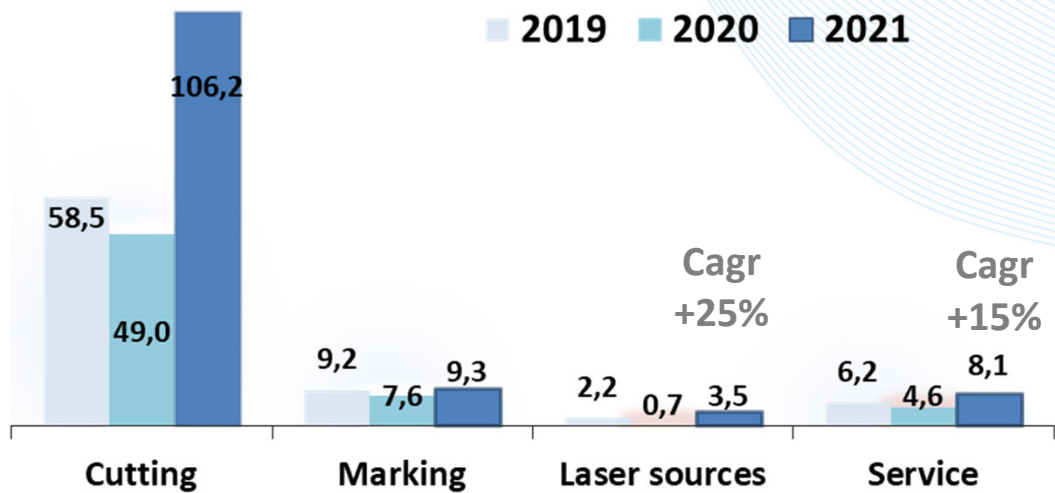

**Industrial**  
Cagr 19/21:  
+29%

*in Euro million*



# Revenue breakdown by area

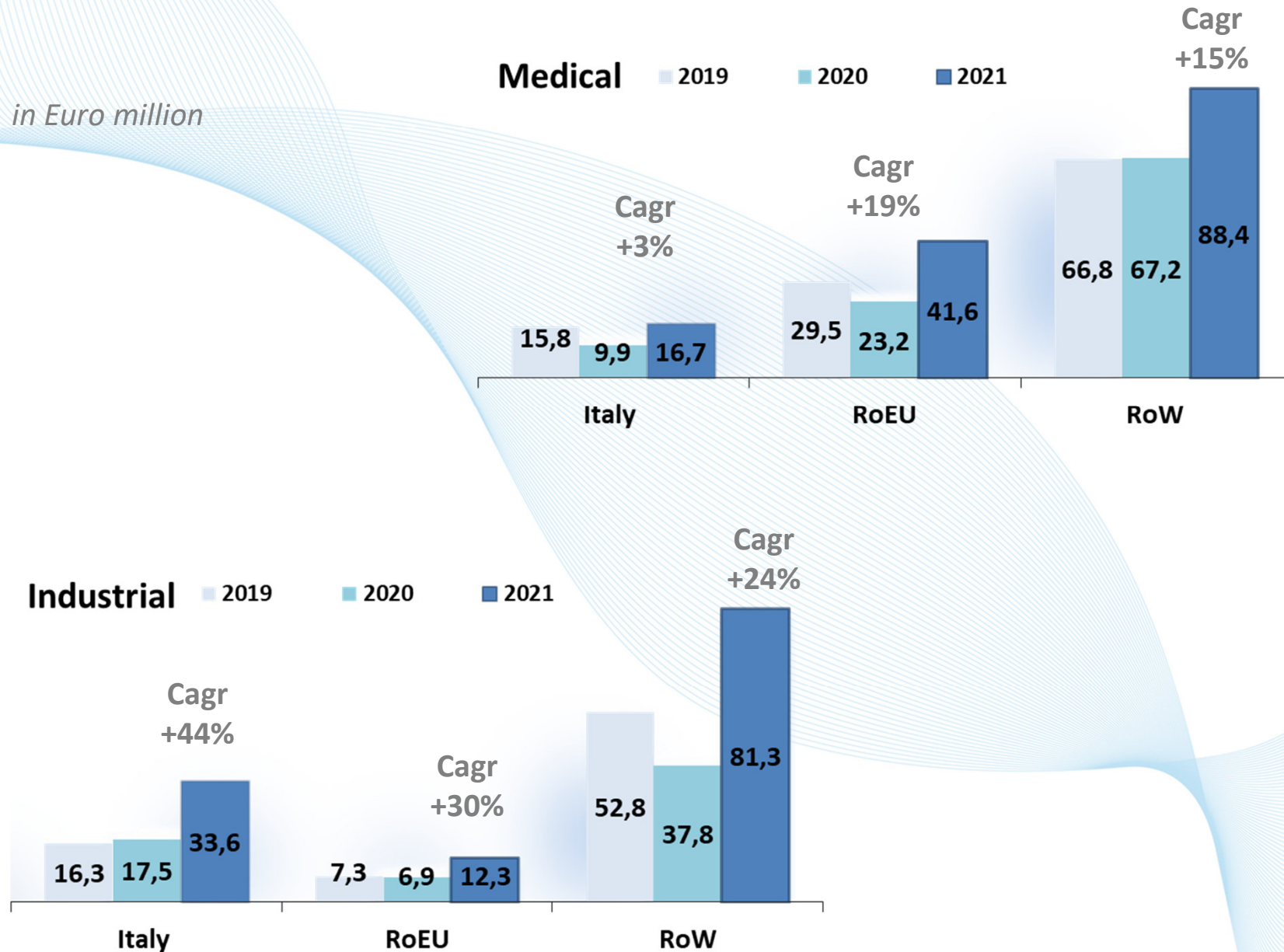



Current Outlook



# 2021 Guidance



**2021 vs 2020:**

**Revenue target >550 mln €**

**EBIT H2  $\geq$  EBIT H1**





# Multiples & Comparables



# Multiples



**Stockholder's Equity per share** **3,3**

**Price / Book Value Adj.** **4,4**

**EV / EBIT (90% EBIT)** **19,1**

**EV / Sales (90% Sales)** **2,2**

**El.En. Market Cap.** **1.155,9 @ € 14,50**

**Net financial position** **78,9 @ 30/06/21**

**Financial investments m/l term** **15,3 @ 30/06/21**

**Enterprise Value** **1.061,8**

# Comparables



Amounts in mln

Sept 30th , 2021

	Price	Revenue	Var.% Rev.	EBIT	EBIT %	MK.Cap.	EV	EV/Sales (*)	EV/EBIT (*)	P/Book Value
<b>Medical/Aesthetic</b>										
Cutera	\$51,12	\$108	85%	\$3	3%	\$917	\$765	3,5	118,3	17,2
InMode	\$133,78	\$153	115%	\$68	45%	\$5.110	\$4.781	15,6	35,0	15,4
Venus	\$2,35	\$48	54%	\$(5)	-11%	\$127	\$180	1,9	n.a.	3,4
Sisram Medical	\$1,90	\$125	75%	\$21	17%	\$884	\$789	3,1	18,5	2,6
Lutronic	€ 14,45	€ 58	73%	€ 11	20%	€ 365	€ 395	3,4	17,5	4,5
<b>Industrial</b>										
IPG Photonics Co.	\$174,22	\$717	31%	\$181	25%	\$9.320	\$7.859	5,5	21,7	3,4
Prima Industrie	€ 21,05	€ 184	17%	€ 2	1%	€ 219	€ 303	0,8	71,4	1,3
Han's Laser	¥43,46	¥7.445	45%	¥878	12%	¥46.410	¥48.282	3,2	27,5	4,4
Bystronic	CHF 1.344	CHF 441	18%	CHF 30	7%	CHF 2.460	CHF 1.986	2,3	32,8	3,1
El.En. (1)	€ 14,50	€ 274	69%	€ 31	11%	€ 1.156	€ 1.062	2,2	19,1	4,4

(1) EV and multiplies as for previous slide

(\*) Revenue,Ebit and earnings annualized



# Comparables

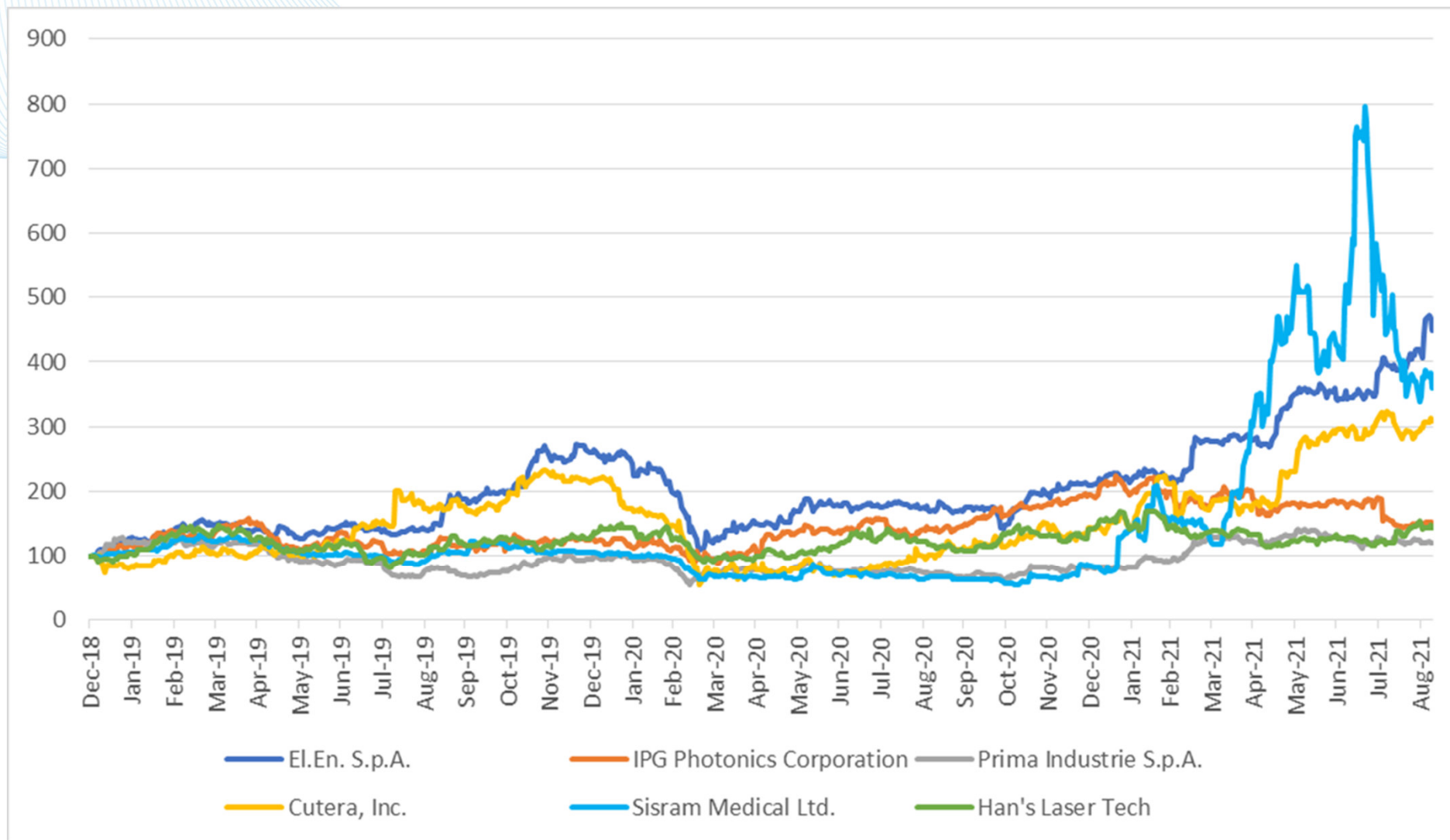

# Contacts

## **El.En. S.P.A.**

Enrico ROMAGNOLI

*Investor Relations Manager*

tel. +39 055-8826807

E-mail: [finance@elen.it](mailto:finance@elen.it)

## **POLYTEMS HIR**

*Financial Communication, IR and Press Office*

Bianca FERSINI MASTELLONI - [b.fersini@polytemshir.it](mailto:b.fersini@polytemshir.it)

Silvia MARONGIU - [s.marongiu@polytemshir.it](mailto:s.marongiu@polytemshir.it)

Tel. +39 06-69923324





**ELEN**<sup>TM</sup>  
— THE FUTURE IN A BEAM —

Industrial and Medical Laser Solutions

